



www.alfatronelectronics.com

ALFATRON ELECTRONICS GmbH GERMANY

ALF-30X-SDIW
User Manual



Attention

This manual introduces functions, installations, and operations for this PTZ camera in detail. Please read this manual carefully before installation and use.

Cautions

Avoid damage to the product caused by heavy pressure, strong vibration, or immersion during transportation, storage, and installation.

Housing of this product is made of organic materials. Do not expose it to any liquid, gas, or solids that may corrode the shell.

Do not expose the product to liquid or moisture.

To prevent the risk of electric shock, do not open the housing. Installation and maintenance should only be carried out by qualified technicians.

Do not use the product beyond the specified temperature, humidity, or power supply specifications.

Wipe it with a soft, dry cloth when cleaning the camera lens. Wipe it gently with a mild detergent if needed. Do not use strong or corrosive detergents to avoid scratching the lens and affecting the image.

This product contains no parts which can be maintained by users themselves. Any damage caused by dismantling the product by the user without permission voids the warranty.

Electrical Safety

Installation and use of this product must strictly comply with local electrical safety standards.

The power supply of the product is $\pm 12V$, the max electrical current is 2A.

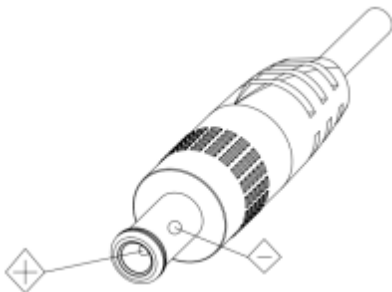

Installation

Do not rotate the camera head forcefully, it may cause mechanical failure.

This product should be placed on a stable desktop or another horizontal surface. Do not install the product obliquely, otherwise, it may display an inclined image.

Ensure there are no obstacles within the rotation range of the holder.

Do not power on before completing the installation.

Magnetic Interference

Electromagnetic fields at specific frequencies may affect the video image. This product is Class A. It may cause radio interference in the household application. The appropriate measure is required.



NOTE: This equipment has been tested and found to comply with the limits for a Class B digital device, pursuant to Part 15 of the FCC Rules. These limits are designed to provide reasonable protection against harmful interference in a residential installation. This equipment generates, uses and can radiate radio frequency energy and, if not installed and used in accordance with the instructions, may cause harmful interference to radio communications. However, there is no guarantee that interference will not occur in a particular installation. If this equipment does cause harmful interference to radio or television reception, which can be determined by turning the equipment off and on, the user is encouraged to try to correct the interference by one or more of the following measures:

- Reorient or relocate the receiving antenna.
- Increase the separation between the equipment and receiver.
- Connect the equipment into an outlet on a circuit different from that to which the receiver is connected.
- Consult the dealer or an experienced radio/TV technician for help.

WARNING: Changes or modifications not expressly approved by the party responsible for compliance could void the user's authority to operate the equipment.

Radiation Exposure

This equipment complies with FCC radiation exposure limits set forth for an uncontrolled environment.

This device complies with Industry Canada licence-exempt RSS standard(s). Operation is subject to the following two conditions:

- (1) this device may not cause interference, and
- (2) this device must accept any interference, including interference that may cause undesired operation of the device.

Radiation Exposure:

This equipment complies with IC radiation exposure limits set forth for an uncontrolled environment.



Do not dispose of this product with the normal household waste at the end of its life cycle. Return it to a collection point for the recycling of electrical and electronic devices. This is indicated by the symbol on the product, user manual or packaging

The materials are reusable according to their markings. By reusing, recycling or other forms of utilization of old devices you make an important contribution to the protection of our environment.

Please contact your local authorities for details about collection points.

Content

1. Fast Installation	6
1.1 Camera Interface Explanation.....	6
1.2 Initial power on configuration	6
1.3 Video Output	6
1.4 Bracket	7
2. Product overview.....	9
2.1 Product Introduction.....	9
2.1.1 Dimension	9
2.1.2 Accessory	9
2.2 Main Features	10
2.2.1 Camera Performance	10
2.2.2 Network performance	10
2.3 Technical Specification	11
2.4 Interface Instruction	12
2.4.1 External Interface.....	12
2.4.3 RS-232 Interface.....	12
3. Application Instruction	14
3.1 Video Output	14
3.1.1 Power-On Initial Configuration	14
3.1.2 Video Output	14
3.2 Remote Controller	14
3.2.1 Keys Instruction	14
3.2.2 Applications	15
3.3 MENU SETTING	17
3.3.1 Main Menu	17
3.3.2 System Setting.....	17
3.3.3 Camera Setting.....	18
3.3.4 P/T/Z.....	20
3.3.5 Video Format	21
3.3.6 Version	21
3.3.7 Restore Default.	21
4. Network Connection	22
4.1 Connecting Mode:	22
4.2 IE Log In.....	25
4.2.1 Web client	25
4.2.2 Preview	25
4.2.3 Configuration	25
4.2.5 Video configuration	26
4.2.6 Network configuration.....	28
4.2.7 System configuration	28
4.2.8 Logout	29
5. Serial Communication Control.....	30

5.1 VISCA protocol list.....	30
5.1.1 Camera return command.....	30
5.1.2 Camera control command	30
5.1.3, Inquiry command.....	33
5.2, Pelco-D protocol command list.....	35
5.3 Pelco-P protocol command list	36
6. Camera Maintenance and Troubleshooting	37
6.1 Camera Maintenance.....	37
6.2 Troubleshooting.....	37
7. Warranty.....	39

1. Fast Installation

1.1 Camera Interface Explanation

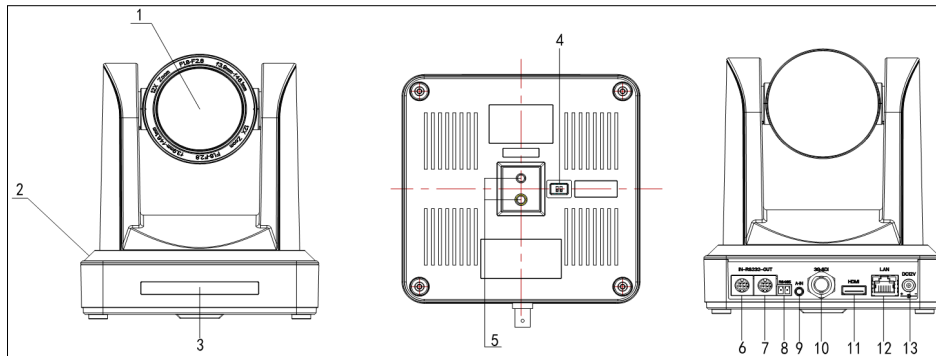

Figure 1.1 Interface

- | | |
|-------------------------------------|-------------------------------------|
| 1. Camera Lens | 8. RS485 Input (left +, right-) |
| 2. Camera Base | 9. Audio Input Interface |
| 3. Remote Controller Receiver Light | 10. 3G-SDI interface |
| 4. Bottom Dial Switch | 11. HDMI Interface |
| 5. Tripod Screw Hole | 12. 10/100M Network Interface |
| 6. RS232 Control Interface (input) | 13. DC12V Input Power Supply Socket |
| 7. RS232 Control Interface (output) | |

1.2 Initial power on configuration

- 1) Connect DC12V power supply adapter with power supply socket.
- 2) Initial configuration: Power on with power indicator light on and remote-control receiver light blinking, camera head moves from bottom left to the bottom, and then goes to the HOME position (intermediate position of both horizontal and vertical), while the camera module focuses in and out. When remote control receiver light stops blinking, the self-checking is completed.

Note: If you set preset 0, when Power on self-test is completed, the camera automatically moves to the preset 0 position.

1.3 Video Output

This camera has a variety of video outputs: LAN, HDMI and 3G-SDI.

- 1) Video Output from LAN
 - a. Network Cable Connection Port: No.12 in Figure1.1.
 - b. Webpage Login: Open your browser and enter **192.168.5.163** in the address bar (factory default); press Enter to open the login page. Enter the username *admin* and password *admin* (factory default); press Enter to enter the preview page, users can carry out PTZ control, configuration etc.
- 2) HDMI Video Output
 - a. HDMI Video Cable Connection: No.11 in Figure1.1.
 - b. Connect the camera to the monitor via an HDMI video cable. The video output is available after camera self-test.
- 3) 3G-SDI Video Output
 - a. 3G-SDI video cable connection: No.10 in Figure1.1
 - b. Connect the camera and the monitor via 3G-SDI video cable; video output is available after camera self-test.

1.4 Bracket

Note: Bracket can only be wall mounted or upside down mounted on template and concrete wall but cannot be installed on plasterboard.

1) Wall mount step

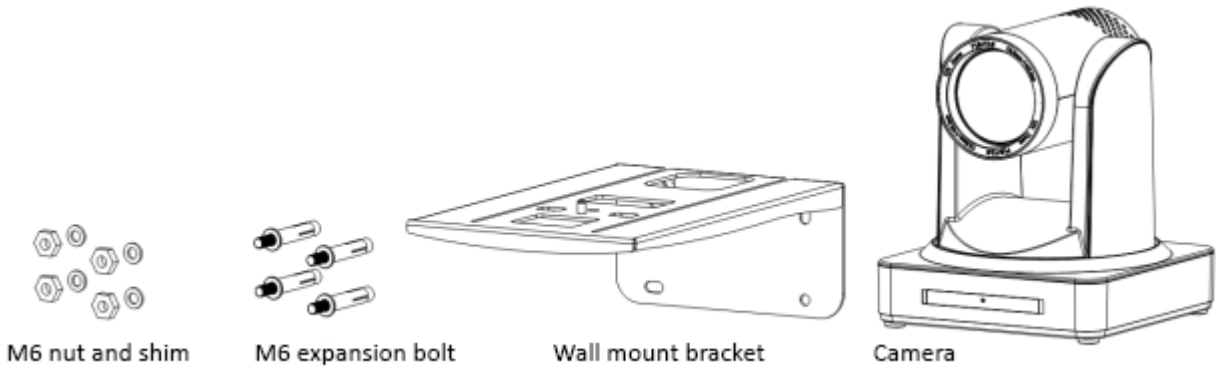

Step 1

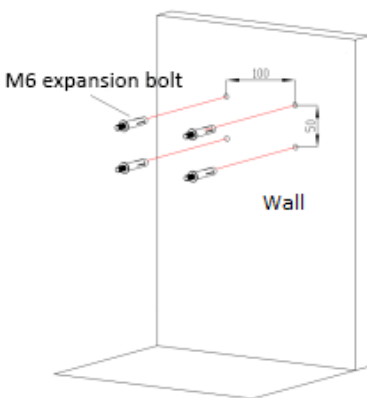

Step2

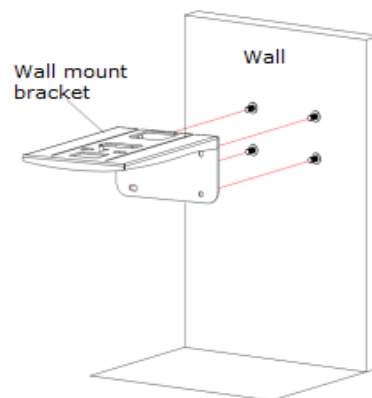

Step3

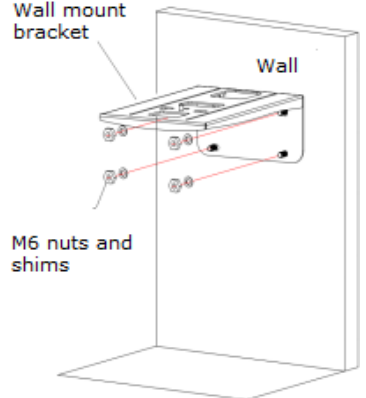

Finish

Step4

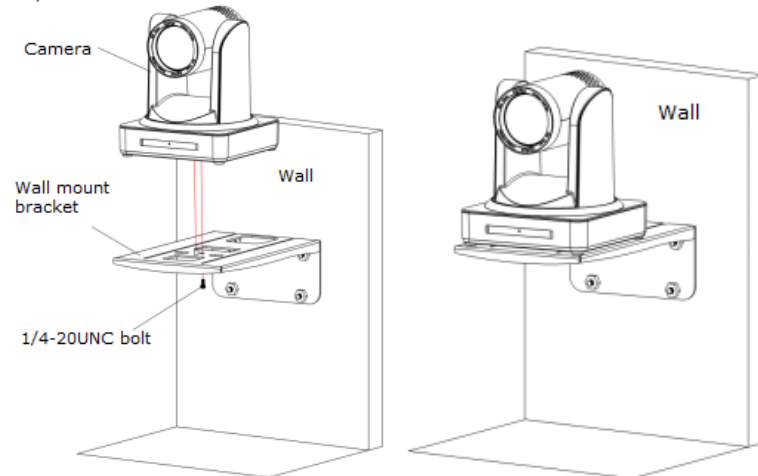

2. Upside down mount step

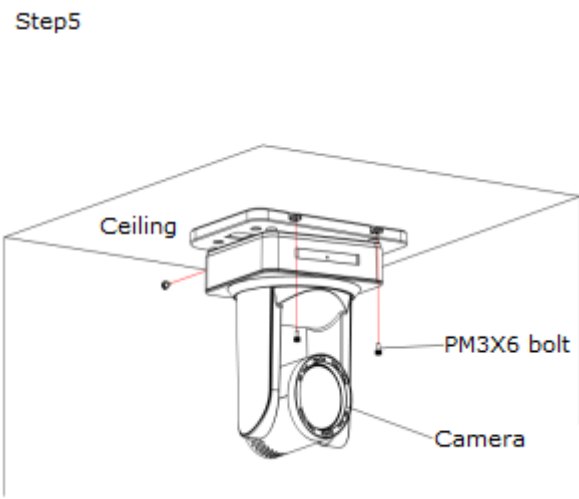
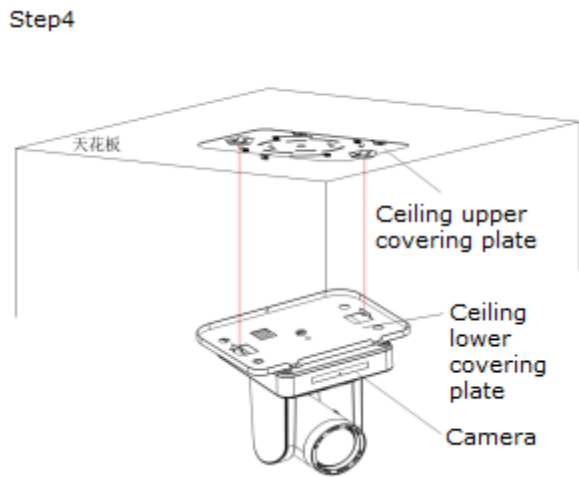
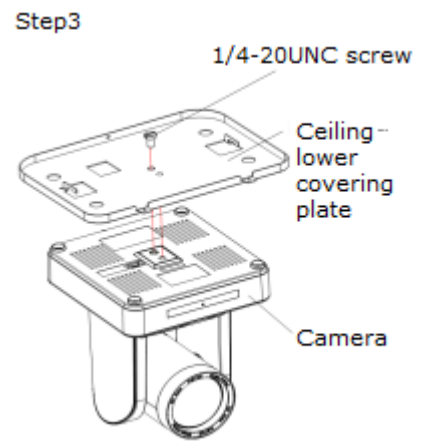
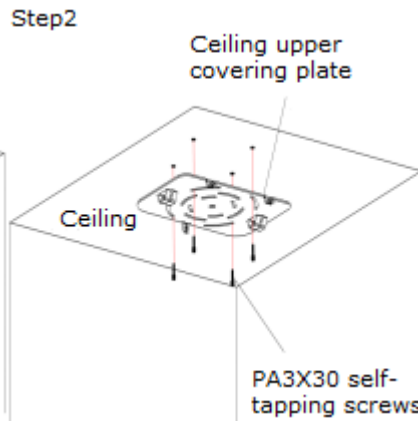
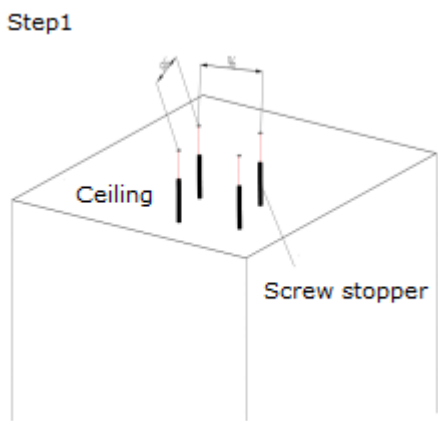
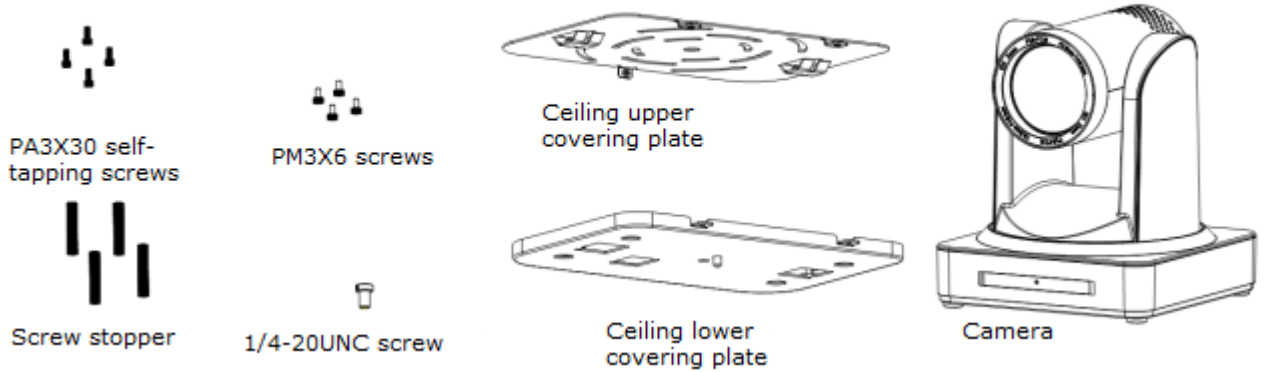

2. Product overview

2.1 Product Introduction

2.1.1 Dimension

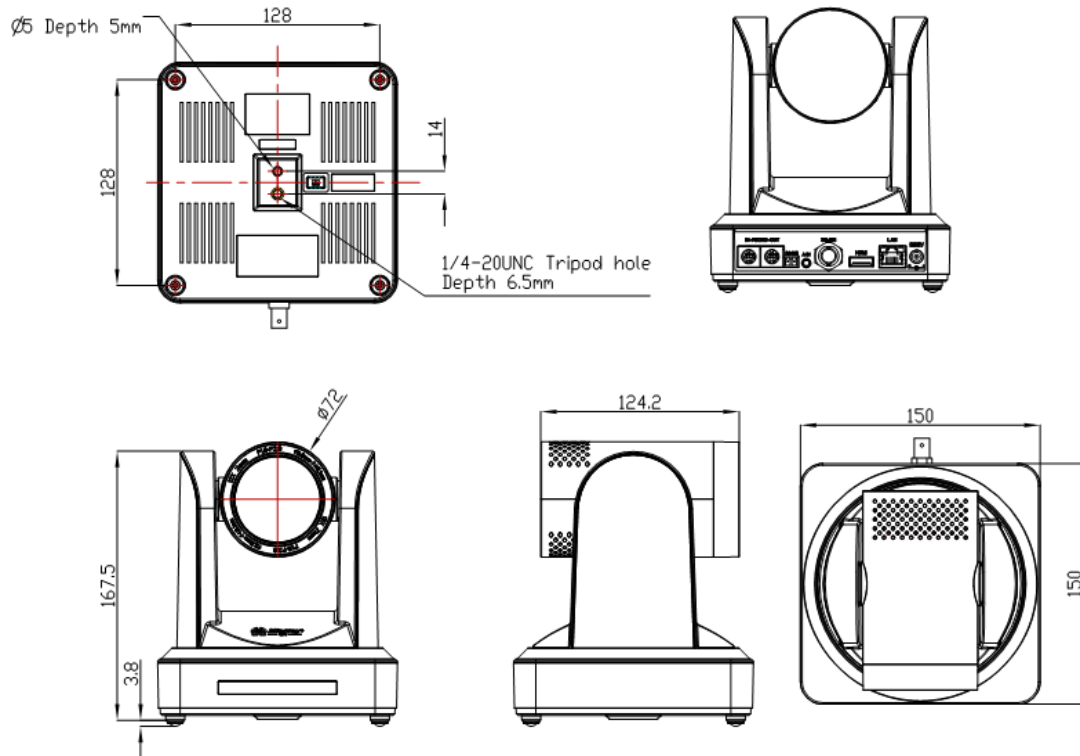

Figure 2.2 Camera dimension

2.1.2 Accessory

When you unpack, check that all the supplied accessories are included:

Model NO.	Configuration	
Accessory	Standard	Power adapter 1piece
		RS232 cable 1 piece
		User manual 1
		Double-side glue shim 4pcs
		Warranty card 1 piece
		IR Remote controller 1 piece
		Wall or Ceiling mounting bracket
		Cascade cable

2.2 Main Features

2.2.1 Camera Performance

This camera offers excellent functionality, superior performance, and superb interfaces. The features include advanced ISP processing algorithms to provide vivid images with a strong sense of depth, high resolution, and fantastic color rendition. It supports H.265/H.264 encoding which makes motion video smooth and clear even with less-than-ideal bandwidth conditions.

1. **Superb High-definition Image:** It employs 1/2.8-inch-high quality CMOS sensor. Resolution is up to 1920x1080 with frame rate up to 60 fps.

2. **Various Optical Zoom Lens:** It has a 30X optical zoom lens.

3. **Leading Auto Focus Technology:** Leading auto focus algorithm makes the lens a fast, accurate and stable.

4. **Low Noise and High SNR:** Low Noise CMOS effectively ensure high SNR of camera video.

Advanced 2D/3D noise reduction technology is also used to further reduce the noise, while ensuring image sharpness.

5. **Quiet PTZ:** By adopting a high accuracy step driving motor mechanism, the Pan / Tilt / Zoom works quietly and moves smoothly and quickly to designated positions.

6. **Multi-Format Video Outputs:** support HDMI,3G-SDI, wired LAN interface. The 3G-SDI is available for 100m transmission at 1080p60 format.

7. **Low-power Sleep Function:** Support low-power sleep/wake up, the consumption is lower than 500mW under sleep mode.

8. **Support Multiple Control Protocol:** Support VISCA, PELCO-D, PELCO-P protocols which can also be automatically recognized. Support VISCA control protocol through IP port.

9. **RS-232 Cascade Function:** SDI series support RS-232 cascade function which is convenient for installing.

11. **255 Presets Positions:** Up to 255 presets (10 presets via remote controller).

12. **Wide Application:** Tele-education, Lecture capture, Webcasting, Videoconferencing, Tele-training, Tele-medicine, Interrogation and Emergency command systems.

2.2.2 Network performance

1. **Audio Input Interface:** Supports 16000, 32000, 44100, 48000 sampling frequency and AAC, MP3, and PCM audio coding.

2. **Multiple Audio/Video Compression:** Supports H.264/H.265 video compression; AAC, MP3 and PCM audio compression; Supports compression of resolution up to 1920x1080 with a frame rate up to 60 fps and 2 channel 1920x1080p with 30 fps compression.

3. **Multiple network protocols:** Support ONVIF, RTSP, RTMP protocols and RTMP push mode, easy to link to streaming media servers like YouTube and Facebook)

2.3 Technical Specification

Model	30X				
Camera Parameter					
Sensor	1/2.8 inch high quality HD CMOS sensor				
Effective Pixels	16: 9, 2.07 megapixel				
Video Format	HDMI/SDI video format 1080P60/50/30/25/59.94/29.97;1080I60/50/59.94;720P60/50/30/25/59.94/29.97				
Optical Zoom	30X f = 4.3 ~ 129mm				
View Angle	2.34°(tele)--65. 1°(wide)				
AV	F1.6 ~ F4.7				
Digital Zoom	10X				
Minimum Illumination	0.5Lux (F1.8, AGC ON)				
DNR	2D & 3D DNR				
White Balance	Auto / Manual/ One Push/ 3000K/ 4000K/5000K/6500K				
Focus	Auto/Manual				
Aperture	Auto/Manual				
Electronic Shutter	Auto/Manual				
BLC	ON/OFF				
WDR	OFF/ Dynamic level adjustment				
Video adjustment	Brightness, Color, Saturation, Contrast, Sharpness, B/W mode, Gamma curve				
SNR	>55dB				

Input/Output Interface	
Video Interfaces	HDMI, 3G-SDI, LAN, Audio-in
Image code stream	Double streams outputs simultaneously
Video Compression format	H.264, H.265
Control Signal Interface	RS-232 Ring through RS232 output, RS-485
Control Protocol	VISCA/Pelco-D/Pelco-P; Baud Rate: 115200/9600/4800/2400bps
Audio input Interface	Double track 3.5mm linear input;
Audio Compression Format	AAC/MP3/PMC Audio compression
HD IP Interface	100M IP port (100BASE-TX); support IP Visca control protocol
Network Protocol	RTSP/ RTMP, ONVIF
Power Interface	HEC3800 outlet (DC12V)

PTZ Parameter	
Pan Rotation	±170°
Tilt Rotation	-30°~+90°
Pan Control Speed	0.1 -180°/sec
Tilt Control Speed	0.1-80°/sec
Preset Speed	Pan: 60°/sec, Tilt: 30°/sec
Preset Number	255 presets (10 presets by remote controller)
Other Parameter	
Supply Adapter	AC110V-AC220V to DC12V/2A
Input Voltage	DC12V±10%
Input Current	1A(Max)
Consumption	12W (Max)
Store Temperature	-10°C to +60°C
Store Humidity	20% - 95%
Working Temperature	-10°C to +50°C
Working Humidity	20%--80%
Dimension	150mmX150mmX167.5mm
Weight	1.4KG
Working Environment	Indoor

Remote Operation (IP)	Remote Upgrade, Reboot and Reset
Accessory	Power Supply, RS232 Control Cable, Remoter, Manual, Warranty card
Optional Accessory	Bracket

2.4 Interface Instruction

2.4.1 External Interface

- External interface: RS232 Input /Output, RS485 Input, Audio Input, 3G-SDI Output, HDMI Output, LAN, DC12V Power Interface.

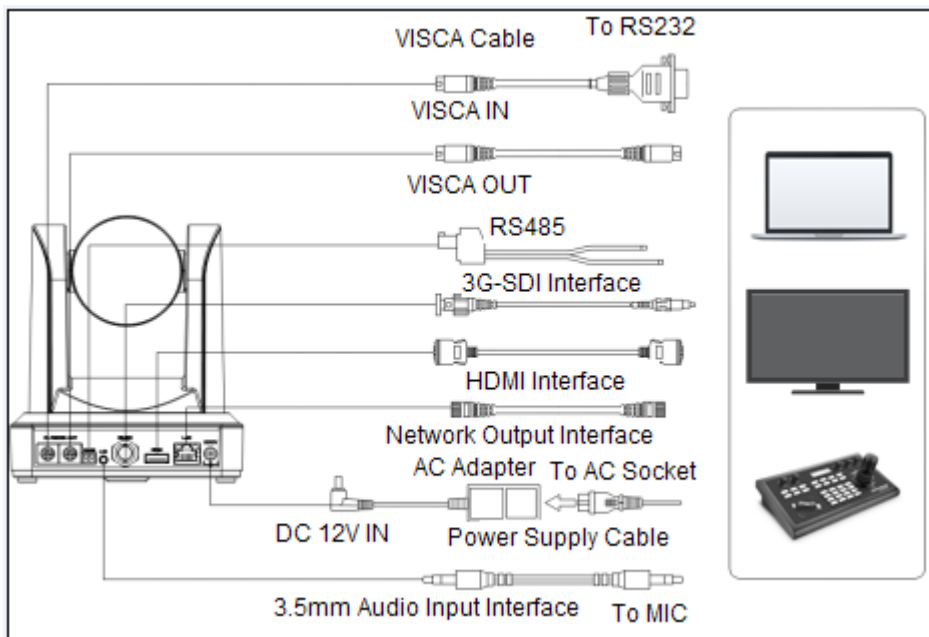
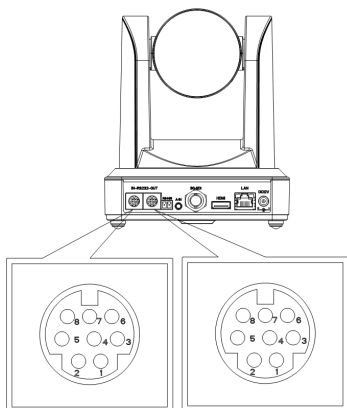

Figure 2.3 External interface diagram

2.4.3 RS-232 Interface

- RS-232C interface specification as shown below:



Computer or keyboard and camera connection method

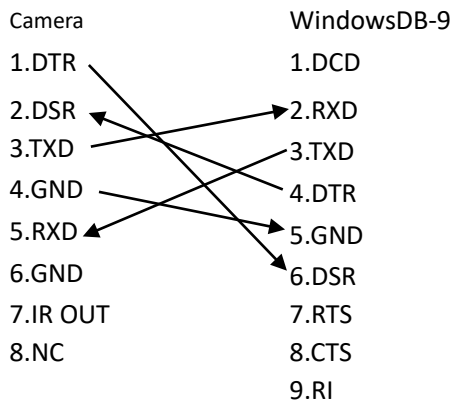

2) RS-232 Mini-DIN 8-pin Port Definition

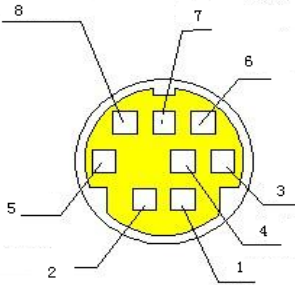

NO.	Port	Definition
1	DTR	Data Terminal Ready
2	DSR	Data Set Ready
3	TXD	Transmit Data
4	GND	System Ground
5	RXD	Receive Data
6	GND	System Ground
7	IR OUT	IR Commander Signal
8	NC	No Connection

3) RS232 (DB9) Port Definition

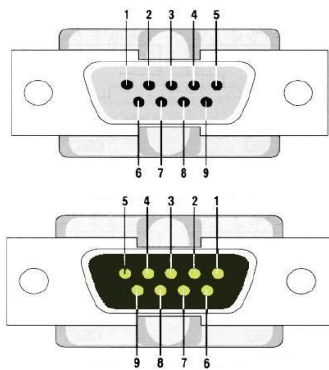

NO.	Port	Definition
1	DCD	Data Carrier Detect
2	RXD	Receive Data
3	TXD	Transmit Data
4	DTR	Data Terminal Ready
5	GND	System Ground
6	DSR	Data Set Ready
7	RTS	Request to Send
8	CTS	Clear to Send
9	RI	Ring Indicator

2) VISCA networking as shown below:

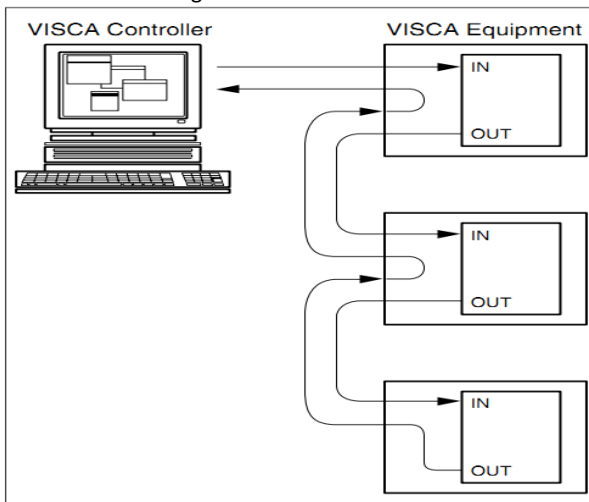

Camera cascade connection method

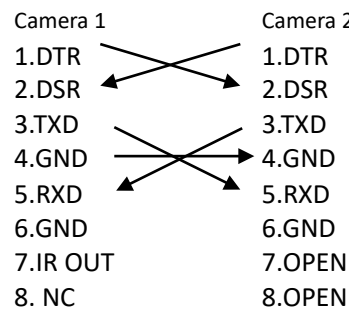

Note: SDI model has RS232 input and output interface, so you can cascade as the above way;

3. Application Instruction

3.1 Video Output

3.1.1 Power-On Initial Configuration

When powered, the camera will run its initial configuration, IR indicator light will be flashing. When the camera returns to the HOME position (middle position for P/T), and lens completes zooming in/out, the auto-testing is completed, and the IR led will stop flashing. If the preset 0 is set, camera will rotate to the 0-preset position after initial configuration.

3.1.2 Video Output

Connect the video output cable. HDMI, SDI or Network

Network output: connect this product and your computer via a network cable, then open the browser, enter the camera IP address (factory default **192.168.5.163**) in the address bar, then to the login page and input a username and password (**factory default username and passwords are "admin"**). Finally enter the preview page, and the image is displayed in preview menu.

(Note: If you forget your username, password, or IP address, you can manually restore the default by the remote controller key combination * #)

2)3G-SDI output or HDMI output: Connect the monitor with the corresponding video output interface, then the monitor output image.

3.2 Remote Controller



3.2.1 Keys Instruction

1. Standby Key

After 3-second-long press, the camera will step into standby mode. Long press for 3 seconds again, the camera will self-test again and move back to the HOME position. (Note: If power-on mode is turned on and Preset 0 is set, and there is no operation within 12s, it will automatically point to the specified preset position.

2. Camera Address Selection

Select the camera **address** which requires control.

3. Number Key

Set or run 0-9 presets.

4. *, # Key

Key combination use

5. Focus Control Key

Auto Focus: Enter auto focus mode.

Manual Focus: The camera focus mode is manual.

Switch the camera focus mode to manual focus by pressing [focus +] or [focus -] to adjust.

6. Zoom Control Key

Zoom + : Lens near

Zoom - : Lens far

7. Set or Clear Preset key:

Set Preset: Set preset key + 0-9 number key:

Clear Preset key: Clear preset key + 0-9 number key

8. Pan/Tilt Control Key

Press ▲ Key :Up

Press ▼ Key :Down

Press ◀ Key :Left

Press ▶ Key: Right

“HOME” Key: Return to the middle position or enter into the next level menu

9. BLC Control Key

Back Light ON / OFF: Turn on or off the back light

10. Menu Setting

Open or close the OSD menu

Enter / exit the OSD menu or return to the previous menu.

11. Camera IR Remote Control Address Setting

- 【*】 + 【#】 + 【F1】 :Camera Address No.1
- 【*】 + 【#】 + 【F2】 :Camera Address No. 2
- 【*】 + 【#】 + 【F3】 :Camera Address No. 3
- 【*】 + 【#】 + 【F4】 :Camera Address No. 4

12. Key Combination Functions

- | | |
|--|---|
| 1) 【#】 + 【#】 + 【#】 :Clear all presets | 2) 【*】 + 【#】 + 【6】 :Restore factory defaults |
| 3) 【*】 + 【#】 + 【9】 :Flip switch | 4) 【*】 + 【#】 +Auto: Enter into the aging mode |
| 5) 【*】 + 【#】 + 【3】 :Menu set to Chinese | 6) 【*】 + 【#】 + 【4】 :Menu set to English |
| 7) 【*】+【#】+Manual: Restore the default user name, password, and IP address | 8) 【#】 + 【#】 + 【0】 :Switch the video format to 1080P60 |
| 9) 【#】 + 【#】 + 【1】 : Switch the video format to 1080P50 | 10) 【#】 + 【#】 + 【2】 :Switch the video format to 1080I60 |
| 11) 【#】 + 【#】 + 【3】 :Switch the video format to 1080I50 | 12) 【#】 + 【#】 + 【4】 :Switch the video format to 720P60 |
| 13) 【#】 + 【#】 + 【5】 :Switch the video format to 720P50 | 14) 【#】 + 【#】 + 【6】 :Switch the video format to 1080P30 |
| 15) 【#】 + 【#】 + 【7】 :Switch the video format to 1080P25 | 16) 【#】 + 【#】 + 【8】 :Switch the video format to 720P30 |
| 17) 【#】 + 【#】 + 【9】 :Switch the video format to 720P25 | |

3.2.2 Applications

Once finalizing initialization, the camera can receive and execute the IR commands. Press the remote controller button, the indicator light is flashing; release the button, the indicator light stops flashing. Users can control the pan/tilt/zoom, setting and running preset positions via the IR remote controller.

Key Instruction:

1. In this instruction, “press the key” means a click rather than a long-press, and a special note will be given if a long-press for more than one second is required.
2. When a key-combination is required, do it in sequence. For example “ 【*】 + 【#】 + 【F1】 ” means press “ 【*】 ” first and then press “ 【#】 ” and last press “ 【F1】 ”.

1) Camera Selection

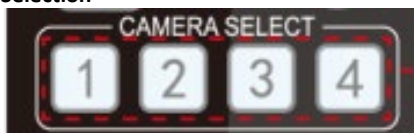

Select the camera address to control.

2) Pan/Tilt Control



Up: press ▲ Down: press ▼
 Left: press ◀ Right: press ▶
 Back to middle position: press “ 【HOME】 ”

Press and hold the up/down/left/right key, the pan/tilt will keep running, from slow to fast, until it runs to the endpoint; the pan/tilt running stops as soon as the key is released.

3) Zoom Control

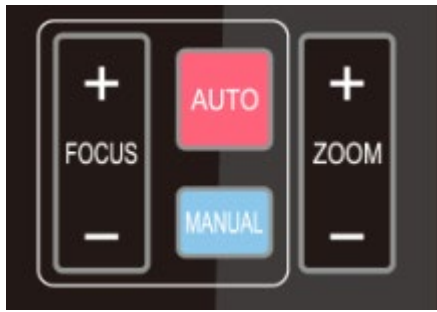

4) Focus Control

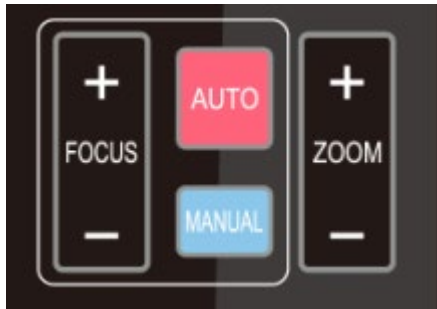

ZOOM IN: press “ZOOM +” key
 ZOOM OUT: press “ZOOM -” key
 Press and hold the key, the camera will keep zooming in or zooming out and stops as soon as the key is released.

Focus (near): Press “【focus+】” key (Valid only in manual focus mode)
 Focus (far): Press “【focus-】”key (Valid only in manual focus mode)
 Auto Focus: Support
 Manual Focus: Support
 Press and hold the key, the action of focus will keep continuing and stops as soon as the key is released.

5) BLC Setting



BLC ON / OFF: support

6) Presets Setting, Running, Clearing



1. Preset setting: to set a preset position, the users should press the “【SET PRESET】” key first and then press the number key 0-9 to set a relative preset,
Note: 10 preset positions in total are available by remote controller.

2. **Preset Running:** Press a number key 0-9 directly to run the relative preset.
 Note: Action in vain if a relative preset position is not existed.

3. Preset clearing: to clear a preset position, the user can press the “【CLEAR PRESET】” key first and then press the number key 0-9 to clear the relative preset:
Note: press the “【#】” key three times continually to cancel all the presets.

7) Camera Remote Controller Address Setting

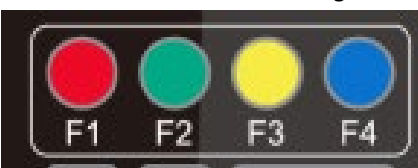

【*】 + 【#】 + 【F1】 :Camera Address No.1
 【*】 + 【#】 + 【F2】 :Camera Address No. 2
 【*】 + 【#】 + 【F3】 :Camera Address No. 3
 【*】 + 【#】 + 【F4】 :Camera Address No. 4

3.3 MENU SETTING

3.3.1 Main Menu

In normal working mode, press **【MENU】** key to display the menu, using scroll arrow to point at or highlight the selected items.

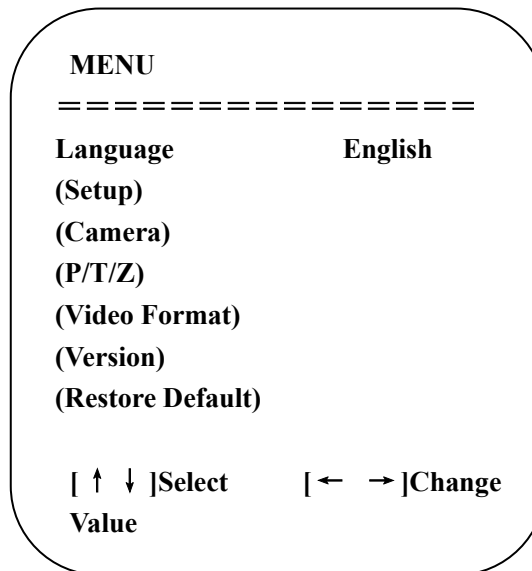

LANGUAGE: Language setting, Chinese / English

SETUP: System setting

CAMERA OPTION: Camera setting

PTZ OPTION: Pan tilt setting

VERSON: camera version setting

Restore Default: Reset setting

[↑↓] **Select:** for selecting menu.

[← →] **Change Value:** for modify parameters.

[MENU] **Back:** Press [MENU] to return.

[Home] **OK:** Press [Home] to confirm.

3.3.2 System Setting

Move the pointer to the (Setup) in the Main Menu, click the **【HOME】** key and enter the (System Setting) as shown below:

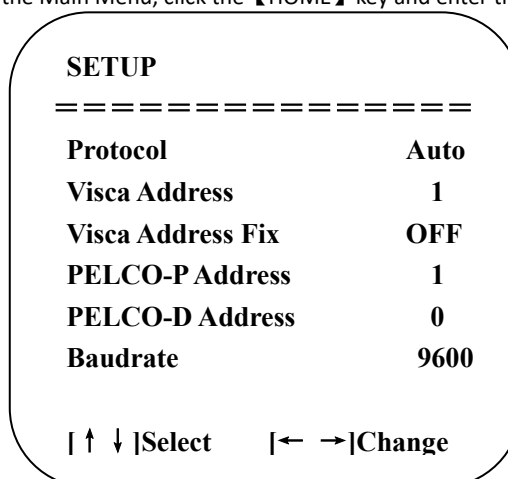

PROTOCOL: VISCA/Pelco-P/Pelco-D/Auto

Visca ADDR: VISCA=1~7 Pelco-P=1~255 Pelco-D = 1~255

Baud rate: 2400/4800/9600/115200

Visca Address Fix: On/Off

3.3.3 Camera Setting

Move the pointer to the (CAMERA) in the Main Menu, click the **【HOME】** key and enter the (CAMERA) as follows:

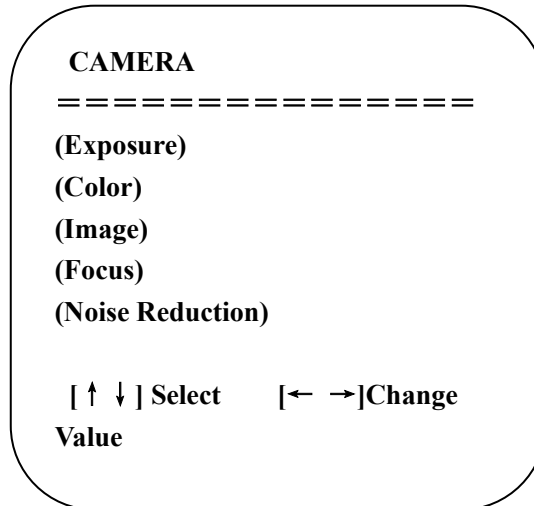

- EXPOSURE:** Enter Exposure setting.
- COLOR:** Enter color setting.
- Image:** Enter image setting.
- Focus:** Enter into focus setting.
- Noise Reduction:** Enter into noise reduction.

1) EXPOSURE SETTING

Move the pointer to the (EXPOSURE) in the Main Menu, click the **【HOME】** and enter the (EXPOSURE SET) as follows:

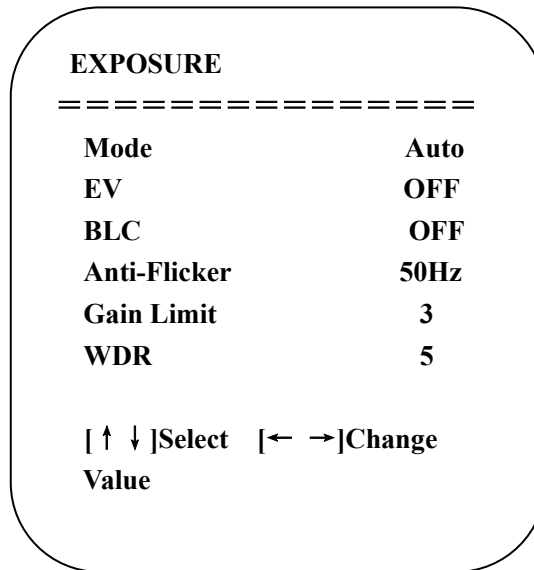

Mode: Auto, Manual, Shutter priority, Iris priority and Brightness priority.

EV: On/Off (only available in auto mode)

Compensation Level: -7~7 (only available in auto mode when EV is ON)

BLC: ON/OFF for options (only available in auto mode)

Anti-Flicker: OFF/50Hz/60Hz for options (only available in Auto/Iris **priority**/Brightness **priority** modes)

Gain Limit: 0~15(only available in Auto/ Iris **priority** /Brightness **priority** mode)

WDR: Off,1~8

Shutter

Priority:1/25,1/30,1/50,1/60,1/90,1/100,1/120,1/180,1/250,1/350,1/500,1/1000,1/2000,1/3000,1/4000,1/6000,1/10000(only available in Manual and Shutter priority mode)

IRIS Priority: OFF, F11.0, F9.6, F8.0, F6.8, F5.6, F4.8, F4.0, F3.4, F2.8, F2.4, F2.0, F1.8 (only available in Manual and Iris priority mode)

Brightness: 0~23 (only available in Brightness **priority** mode)

2) COLOR SETTING

Move the pointer to the (COLOR) in the Main Menu, click the **【HOME】** and enter the (COLOR SET) as follow,

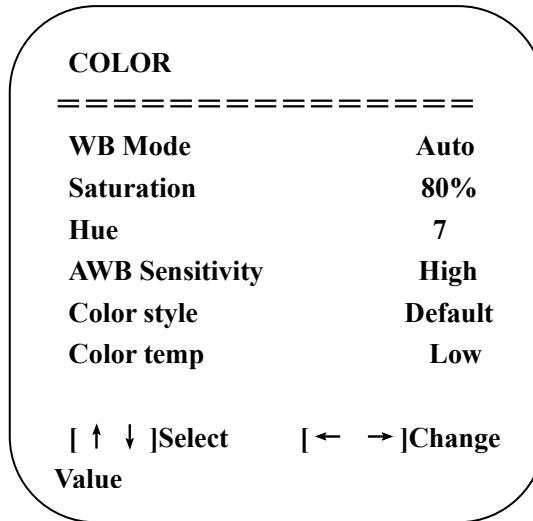

WB Mode: Auto, 3000K、 3500K、 4000K、 4500K、 5000K、 5500K、 6000K、 6500K、 7000K, Manual, One Push

Red Gain: 0~255(only available in Manual mode)

Blue Gain: 0~255(only available in Manual mode)

Saturation: 60%,70%,80%,90%,100%,110%,120%,130%

Hue: 0~14

AWB Sensitivity: high/middle/low

Color Style: Default, style1~4.

Color Temp: high/middle/low

3) IMAGE

Move the pointer to the (IMAGE) in the Menu, click the **【HOME】** and enter the (IMAGE) as follow,

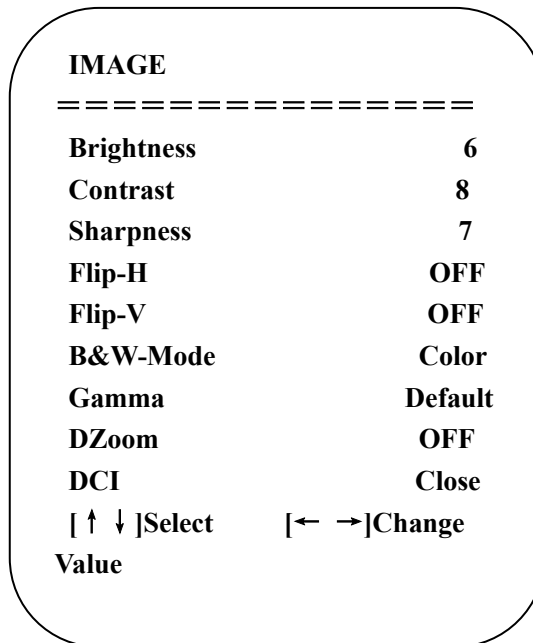

Brightness: 0~14

Contrast: 0~14

Sharpness: 0~15

Flip-H: On/Off

Flip-V: On/Off

B&W Mode: color, black/white
Gamma: default, 0.47, 0.50, 0.52, 0.55
DZoom: digital zoom options: On/Off
DCI: Dynamic Contrast: Off,1~8

4) FOCUS

Move the pointer to the (FOCUS) in the Menu, click the **【HOME】** and enter the (FOCUS) as follow,

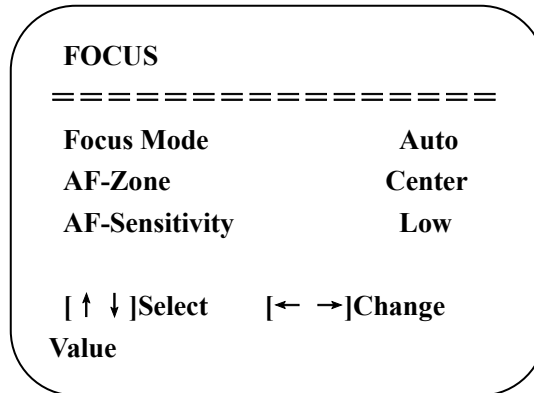

Focus Mode: Auto, manual
AF-Zone: Up, middle, down
AF-Sensitivity: High, middle, low

5) NOISE REDUCTION

Move the pointer to the (NOISE REDUCTION) in the Menu, click the **【HOME】** and enter the (NOISE REDUCTION) as follows:

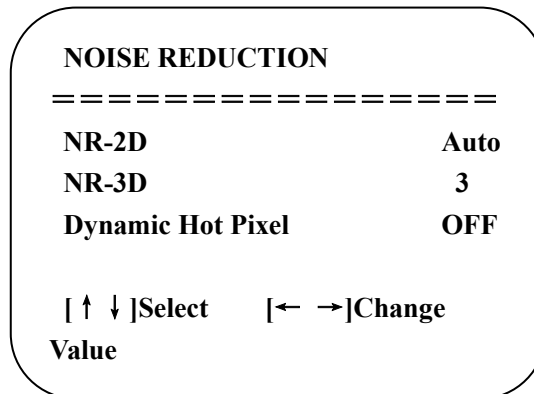

2D Noise Reduction: Auto, close, 1~7
3D Noise Reduction: Close, 1~8
Dynamic Hot Pixel: Close, 1~5

3.3.4 P/T/Z

Move the pointer to the (P/T/Z) in the Main Menu, click the **【HOME】** and enter the (P/T/Z) as follow,

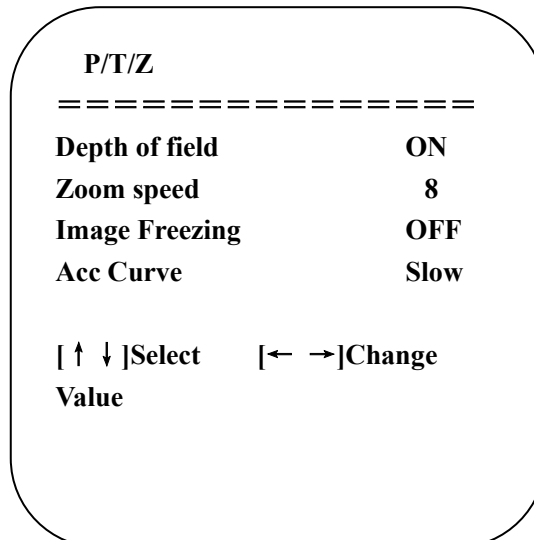

Depth of Field: Only effective for remote controller, On/ Off;
 When zoom in, the PT control speed by remoter will become slow),
Zoom Speed: Set the zoom speed for remote controller,1~8
Image Freezing: On/Off
Accelerating Curve: Fast/slow

3.3.5 Video Format

Move the pointer to the (Video Format) in the Menu, click the **【HOME】** and enter the (Video Format) as follows:

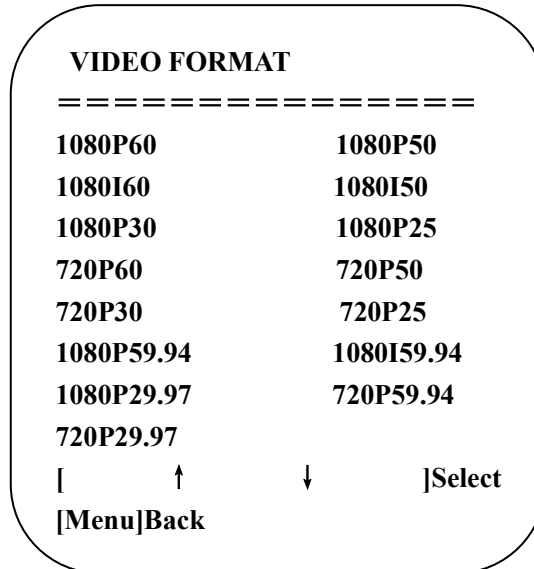

Note: 1. 1080P60 Downward Compatibility;
 2. Exit menu after modifying parameter to save it after powering off.

Version: 1080P60, 1080P50, 1080P30, 1080P25, 1080I60, 1080I50, 720P60, 720P50, 720P30, 720P25, 1080P59.94, 1080I59.94, 1080P29.97, 720P59.94, 720P29.97

3.3.6 Version

Move the pointer to the (VERSION) in the Main Menu, click the **【HOME】** and enter the (VERSION) as follow,

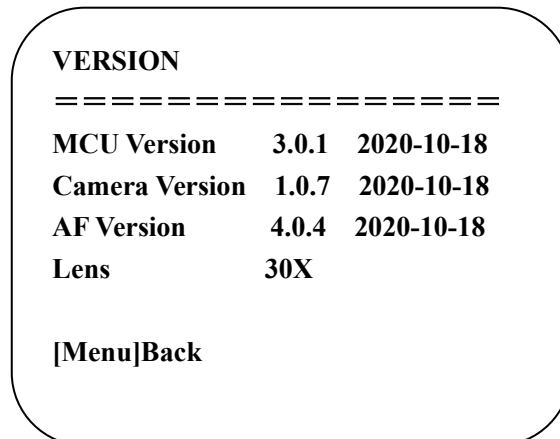

MCU Version: Display MCU version information.
Camera Version: Display camera version information.
AF Version: Display the focus version information.
Lens: Display the lens zoom.

3.3.7 Restore Default.

Move the pointer to the (RESTORE DEFAULT) in the Main Menu, click the **【HOME】** and enter the (RESTORE DEFAULT) as follow,

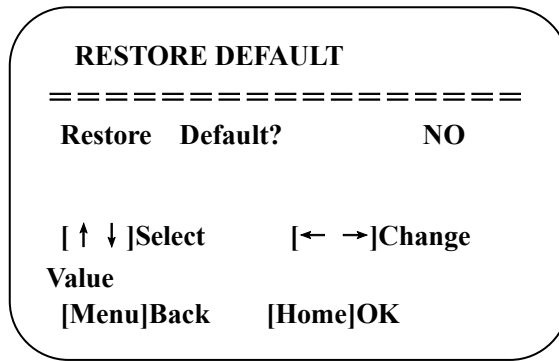

Restore default: options: yes/no; after restoring default, the video format will not be restored.

Note: If the address of former remoter is not 1 but another one from 2,3,4, the corresponding camera address will restore to 1 when all parameters or system parameters are restored. User should change the remoter address to be 1 (press No.1 according to the camera so to get normal operation)

4. Network Connection

4.1 Connecting Mode:

Direct connection: Connect the camera and computer by network connecting cable.

Internet connection mode: Connect the camera to Internet by Router or Switch and user can log in the device via browser.

Note: Please do not put the power and network cable in places where can be easily handled, to prevent video quality lowered by unstable signal transmission due to poor contact of cables.

The computer must have the network segment where the camera IP address belongs to. The device will not be accessible without the segment. E.G. The camera default IP address is **192.168.5.163**, then segment 5 must be added in the computer. Specific steps are as below:

Firstly, open the window of Local Area Connection Properties on computer, select the “Internet protocol version 4(TCP/IPv4)” as shown by picture on the left. Double click or click the property “Internet” protocol version 4 (TCP/IPv4) to enter into the Internet Protocol Version 4 (TCP/IPv4) Properties window, select “Advanced” to enter the Advanced TCP/IP Setting and add IP and subnet mask in the IP browser as pictured below. Click the “Confirm” to finish the adding of IP segment. User can add the corresponding network segment according to the revised IP address of the camera.

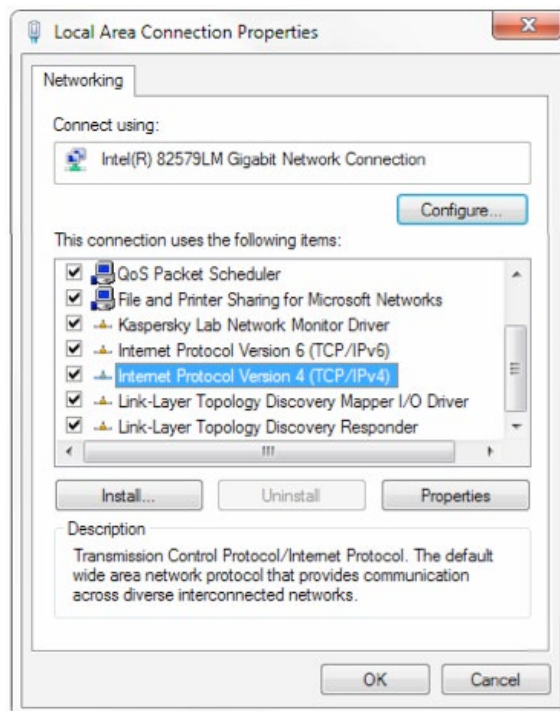

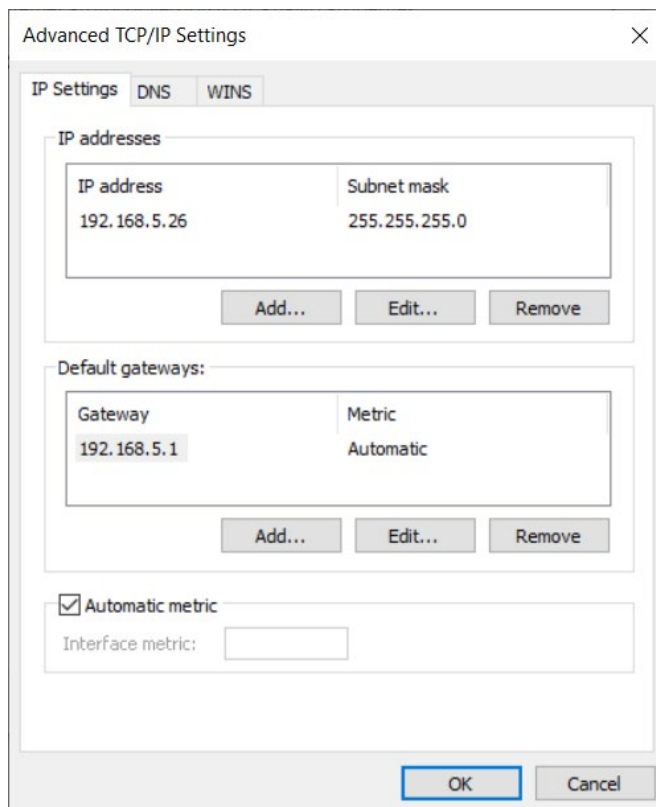
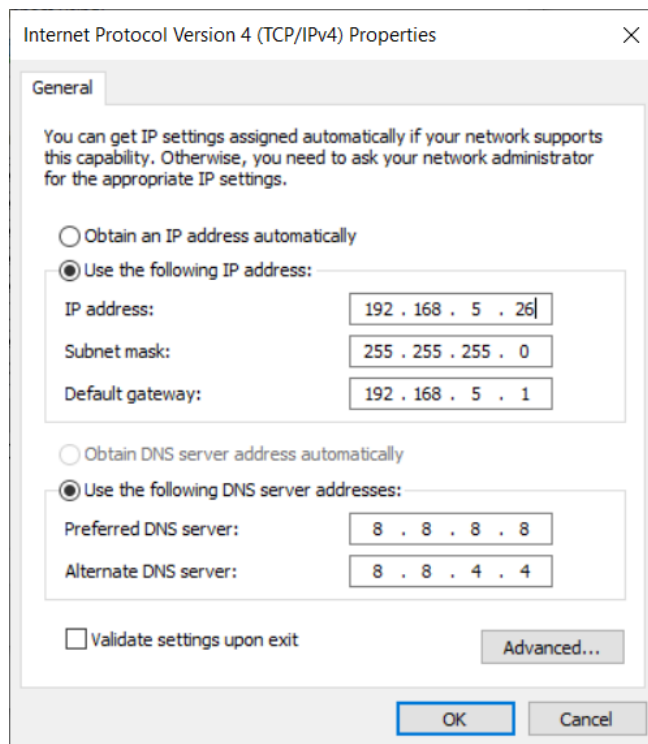

Note: The IP address to be added cannot be same as other computers or devices. The existence of this IP address needs to be verified before adding.

Click the “Start” and select “Operation” to input CMD as picture below to verify if the network segment has been successfully added.

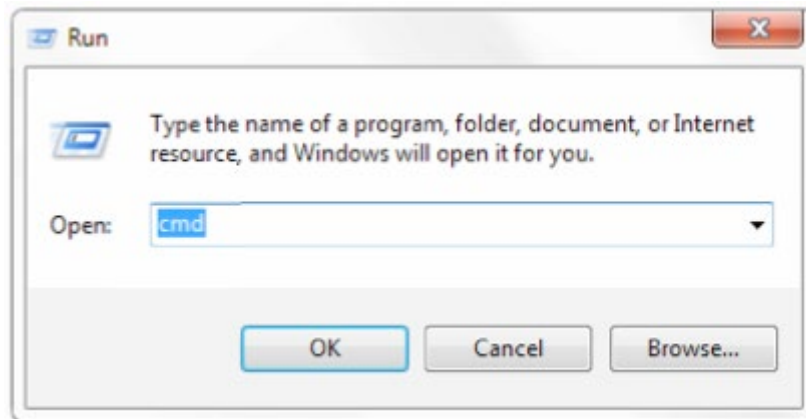

Click “OK” and open the DOS command window, input “ping 192.168.5.26” and press Enter key, it will show message as below: which means network segment adding is successful.

```
C:\Users\qq214>ping 192.168.5.26

Pinging 192.168.5.26 with 32 bytes of data:
Reply from 192.168.5.26: bytes=32 time<1ms TTL=128
Reply from 192.168.5.26: bytes=32 time=1ms TTL=128
Reply from 192.168.5.26: bytes=32 time<1ms TTL=128
Reply from 192.168.5.26: bytes=32 time<1ms TTL=128

Ping statistics for 192.168.5.26:
    Packets: Sent = 4, Received = 4, Lost = 0 (0% loss),
    Approximate round trip times in milli-seconds:
        Minimum = 0ms, Maximum = 1ms, Average = 0ms

C:\Users\qq214>
```

User can also to verify network connection as steps above mentioned after the finish of camera self-check. If IP is default, open DOS command window and input 192.168.5.163, then press Enter key. It will show message as below: which means network connection is normal.

```
C:\Users\qq214>ping 192.168.5.163

Pinging 192.168.5.163 with 32 bytes of data:
Reply from 192.168.5.163: bytes=32 time=2ms TTL=64
Reply from 192.168.5.163: bytes=32 time=1ms TTL=64
Reply from 192.168.5.163: bytes=32 time<1ms TTL=64
Reply from 192.168.5.163: bytes=32 time=4ms TTL=64

Ping statistics for 192.168.5.163:
    Packets: Sent = 4, Received = 4, Lost = 0 (0% loss),
    Approximate round trip times in milli-seconds:
        Minimum = 0ms, Maximum = 4ms, Average = 1ms

C:\Users\qq214>_
```

4.2 IE Log In

4.2.1 Web client

1) Web client Log In

Input the IP address 192.168.5.163 of the device in the address field of the browser and click the 'Enter' button to enter the Web Client login page. User can login as administrator and normal user. If logging in as administrator (Default Username/Password: admin), users can preview, playback, configure and cancel in the Web Client; If login in as normal user (Default Username/Password:user1 or user2), users can only preview, playback and cancel, no option for configuration.

Note: Web access supported browsers: Chrome, Safari, Edge and IE.

4.2.2 Preview

After successful login to the management interface, the video preview interface will be visible. In the preview screen, users can control PTZ, zoom, focus, video capture, sound, focus, full screen and set the preset position, run, delete and other operations.

1) Login as administrator

Username, password, the default is 'admin'

PTZ control can be carried out, zoom, focus, video capture, sound, zoom, full screen and set the preset position, run, and delete; you can preview, playback, configure, and log off.

2) Login as normal user

Default Username/password: user1 or user2

PTZ control can be carried out, zoom, focus, video capture, sound, zoom, full screen and set the preset position, run, and delete; you can preview, playback and log off.

NOTE: There is no configuration rights for normal user login.

4.2.3 Configuration

Click **Configuration** to enter the device parameters setting page.

There are the following options: Local configuration, audio configuration, video configuration, network configuration, PTZ configuration, internet access configuration, system configuration. For detailed description, see the following table:

Menu	Explanation
Local configure	Including video preview mode, record video packing time, record video storage route settings etc.
Audio configure	Including audio compressing format, sampling frequency, sampling precision, compressing code rate settings etc.
Video configure	Including video encoding, video parameters, character-overlapping, character size, video output setting etc.
Network configure	Including basic parameters, Ethernet, DNS, wireless network setting, etc.
System configure	Including equipment property, system time, user management, version update, Reset, Reboot device settings etc.

1) Local configuration

Video Preview Mode: User can choose real-time priority or fluency priority: The delay will be small when under real time priority mode and fluency will be good when under fluency priority mode. Setting based on the users need (Default value: real time normal (2), real time best (1), fluency normal (3), fluency good (4) and fluency best (5))

Recording packing time (minute): Set recording video packing time (default is 10, range from 1~120 minutes)

Recording / Snapshot file storage route: Set local recording video/snapshot file storage route. (Default D:\MyIPCam\)

Click the **Save** button to make settings effective.

2) Audio Configuration

Switch: Choose to enable the audio or not.

Compressing format: Set audio compressing format and the device will reboot automatically after change (default MP3, PCM, AAC optional)

Sampling frequency: Set sampling frequency and the device will reboot automatically after change (default 44100, 16000, 32000 and 48000 optional)

Sampling precision: Set sampling precision (default 16bits)

Compressing code rate: Set audio compressing code rate (default 64bits, 32, 48, 96, 128 bits optional)

Note Click "SAVE", it will remind Enable has changed. Restart the device to take effect after the success of the save., then please reboot the camera to make new setting effect.

4.2.5 Video configuration

1) Video encoding

Code stream: Stream: Different video output mode settings use different streams. (main stream, secondary stream)

Compression Format: Set the video compression format, save and reboot to take it effect (primary / secondary stream default: H.264, H.265 optional)

Video Size: Set video image resolution, save and reboot to take it effect (main stream default 1920 * 1080 or 1280 * 720 optional; default secondary stream 640 * 320, 320 * 180, 1280 * 720, 1920 * 1080 optional)

Stream Rate control: Set rate control mode, save and reboot to take effect (Primary / secondary stream default variable bit rate, fixed rate is for option).

Image Quality: Set the image quality. Image quality can be changed only when rate control is variable bit rate, (main stream defaulted is better, secondary stream default is not good, there are best, better, good, bad, worse, worst for options).

Rate (Kb/s): Set the video bit rate (main stream default 4096Kb / s, 64-12288Kb / s optional; secondary stream default 1024Kb / s, 64-10240Kb / s optional).

Frame rate (F / S): Set the video frame rate (primary / secondary stream default 25F / S, primary stream 5-60F/S optional, secondary stream 5-30F / S optional).

Key frame interval: Set the key frame interval (primary / secondary stream default 75F, primary / stream 1-300F optional. secondary stream 1-150F optional).

Stream Name: When streaming via RTSP or RTMP, user can modify stream name. Main Stream(live/av0), sub stream(live/av1)

Click the "Save" button to display the "saved successfully" message, then settings take effect.

2) Stream Release

Switch: To turn on/off the main / secondary stream.

Protocol: primary / secondary stream applies RTMP protocol.

Host Port: server port number (default 1935, 0-65535 optional)

Host Address: server IP addresses (default 192.168.5.11)

Stream Name: choose a different stream name (live / av0, live / av1 optional).

User: Set the username.

Password: Set the password.

Click on the "Save" button to display the "Save successful" message, for settings to take effect.

Method of obtaining RTSP: rtsp:// device IP address: 554 / live / av0 (av0 mainstream; av1 secondary stream)

3) RTP Broadcasting

Main/Sub Stream: On/off.

Protocol: RTP or TS

Address: Default 224.1.2.3. It can be edited.

Port: Mainstream Default Port: 4000, **Sub Stream Default Port:** 4002

Visit: Address comes up after setting. E.g., rtp://224.1.2.3:4000; udp://@224.1.2.3:4000.

3) Video Parameters

a. Focus: Focus mode, focus range, focus sensitivity can be set.

Focus Mode: set the focus mode (the default auto, manual optional)

Focus range: set the focus range (the default middle, the upper and lower optional)

Focus Sensitivity: Set the focus sensitivity (default is low, high, medium optional)

b. Exposure: Exposure mode, exposure compensation, back light compensation, anti-flicker, gain limit, wide dynamic, shutter speed, aperture value and brightness can be set.

Exposure Mode: Set the exposure mode (the default automatic, manual, shutter priority, aperture priority, brightness priority optional)

Exposure compensation: Exposure compensation setting is active when it is in auto status (default is off).

Exposure compensation value: Set the exposure compensation value, valid when it is set for auto (default 0-7 to 7 optional).

BLC: Set back light compensation, valid when it is in auto status (default is off).

Anti-flicker: Set up anti-flicker mode, valid when status of automatic, aperture or brightness priority (default 50Hz, closed, 60Hz optional).

Gain limit: set the gain limits, auto, active when it is status of aperture or brightness priority (default 3, 0-15 optional).

Dynamic range: set the dynamic range (default 5, 0-8 optional).

Shutter speed: active when it is status of manual or shutter-priority (default 1/100, 1/25, 1/30, 1/50, 1/60, 1/90, 1/100, 1/120, 1/180, 1/250, 1/350, 1/500, 1/1000, 1/2000, 1/3000, 1/4000, 1/6000, 1/10000 optional).

Aperture value: Set the aperture value, active when it is status of manual or aperture-priority (default F1.8, closed, F11, F9.6, F8.0, F6.8, F5.6, F4.8, F4.0, F3.4, F2.8, F2.4, F2.0, F1.8 optional).

Brightness: Set the brightness value, active when it is in a state of brightness priority (default 7, 0-23 optional).

c. Color: White balance, saturation, color, white balance, sensitivity, color temperature, gain red and blue gain can be set.

White balance modes: Set the white balance mode (the default automatic, 3000K, 4000K, 5000K, 6500K, manual, One-push optional). Note: Click the "Correction" button when selected the One-push white balance mode.

Saturation: Set the saturation (default 80%, 60%, 70%, 80%, 90%, 100%, 110%, 120%, 130%, optional).

Auto white balance Sensitivity: Sensitivity Auto white balance settings (default is low, high, medium optional).

Chroma: Set the chrome (default 7, 0-14 optional).

Color Temperature: set color temperature (Default setting: High, with low, middle for options)

Red Gain: Set the red gain, effective when it is manual (default 255, 0-255 optional).

Blue Gain: Sets the Blue gain, effective when it is manual (default 199, 0-255 optional).

d. Image: Brightness, contrast, sharpness, black and white mode, the gamma curve, Horizontal Flip and Vertical Flip can be set.

Brightness: Set the brightness (default 6, 0-14 optional).

Contrast: set the contrast (default 8, 0-14 optional).

Sharpness: Set the sharpness value (default 7, 0-15 optional).

Black and white mode: Set black and white mode (default color, black/white optional).

Gamma: Gamma value setting (default, 0.45, 0.50, 0.52, 0.55 optional).

Flip Horizontal: Set Flip Horizontal (default Off, On optional).

Flip Vertical: Set vertical flip (default Off, On optional).

e. Noise Reduction: 2D noise reduction, 3D noise reduction and dynamic dead pixel correction available.

2D Noise Reduction: Set 2D noise reduction level (default Auto, 1-7 and Off optional).

3D Noise Reduction: Set 3D noise reduction level (default 5, 1-8 and Off optional).

Dynamic dead pixel correction: Set Dynamic dead pixel correction (default Off, 1-8 optional).

Note: Click "Refresh" to make revision of any video parameters of a, b, c, d, and e effective.

4) Character-Overlapping

Display date and time: Set whether to display the time and date (default display).

Display Title: Set whether to display the title (default display).

Font Color of Time: Set font color of time and date (default white, black, yellow, red, blue optional).

Font Color of Title: Set font color of title (default white, black, yellow, red, blue optional).

Moving characters: Set the display position of moving date, time, and title, click on the "up, down, left, right" buttons to move the corresponding character position.

Title Content: Set title content (default CAMERA1).

Time Content: Set time content (default 1970/01/10 05:36:00)

Click on the "Save" button and display the "Save successful" message, then valid

5) Character Size

Mainstream character size: Set the character size of the display, the device will restart automatically after changes are saved (default 24, 24, 16 optional)

Secondary stream character size: Set the character size of the display, the device will restart automatically after changes are saved (default 16, 24, 16 optional)

Click on the "Save" button to display "Parameter saved successfully" message, set to take effect.

6) Video output

Output Format: Set the video output format (default 1080P60, 1080P50, 1080P30, 1080P25, 1080I60, 1080I50, 720P60, 720P50, 720P30, 720P25, 1080P59.94, 1080I59.94, 1080P29.97, 720P59.94, 720P29.97 optional).

Click on the "Save" button, it will be valid when display "Save successful".

7) USB subtitle

Display subtitles: Check the box (after checking, USB video output is displayed on the screen caption content)

Font color: Default white and black. Yellow, red, and blue optional

Subtitle: Users can fill in their own

Ticker: according to the user demand, down, left, and right to move the display position of subtitles

Note: only U3 and U2 model have this item, ST and HD do not have.

4.2.6 Network configuration

1) Network port

Data port: set the data port, the device will restart automatically after changes (default 3000,0-65535 optional).

Web Port: Set Web port, the device will restart automatically after changes (default is 80,0-65535 is optional).

Onvif Port: Set Onvif port, the device will restart automatically after changes (default 2000,0-65535 optional).

Soap Port: Set Soap port (default 1936,0-65535 optional).

RTMP Port: Set RTMP port (default 1935,0-65535 optional).

RTSP Port: Set RTSP port, the device will restart automatically after changes (default 554,0-65535 optional).

Visca IP Port: 1259

Visca Port: Set Visca port, the device will restart automatically after changes (default 3001,0-65535 optional).

Click on the "Save" button, it will be valid when displaying "Save successful".

RTMP access: rtmp://equipment[IP address]:1935/live/av0 (av0 main stream; av1 second stream)

2) Ethernet parameters

DHCP: Enable or disable obtain IP automatically can be set. Save changes and reboot the device to take effect (Default: OFF)

IP Address: Set the IP address, save changes and reboot the device to take effect (default 192.168.5.163).

Note: This IP address is the same with the one used to login to the Web page.

Subnet Mask: Set the subnet mask (default 255.255.255.0).

Default Gateway: Set the default gateway (default 0.0.0.0).

Physical Address: Set the physical address (the parameter is read-only but cannot be modified).

Click on the "Save" button, it will be valid when displaying "Save successful". (Note: To prevent IP conflicts When modified).

3) DNS parameters

Preferred DNS server: set the preferred DNS server. (Default 0.0.0.0).

Alternate DNS server: Alternate DNS server settings. (Default 0.0.0.0).

Click on the "Save" button, it will be valid when displaying "Save successful".

4.2.7 System configuration

1) Device Properties

Device Name: Set the device name (the default Camera1, user can add their own).

Device ID: Set the device ID (default 1, Read-Only).

System Language: Set the system language (default Simplified Chinese, English optional). Need to re-login after modifying and saving the setting.

Click on the "Save" button, it will be valid when display "Save successful".

2) System Time

Date Format: Set the date format (YYYY-MM-DD default That year - month - day, MM-DD-YYYY namely Month - Day - Year, DD-MM-YYYY date - month - year Optional).

Date separator: set the date separator (default '/', '-', '-' Optional).

Time Zone: Set the time zone (default East eight districts, other time zones optional).

Time Type: Set the time types (default 24 hours, optional 12 hours).

Time setting: Set time mode (to choose the computer time synchronization, NTP server time synchronization, or set manually).

Computer Time: Set the computer synchronization valid.

Update interval: Set the NTP server to automatic updated time interval. Valid after setting NTP server synchronization (default one day, 2-10 days Optional).

NTP server address or domain name: Set NTP server address or domain name (default time.nits.gov). Valid after setting NTP server synchronization.

NTP Server Port: Sets the NTP server port (default 123). Valid after setting NTP server synchronization.

Set the time manually, effective when set manually.

Click on the "Save" button, it will be valid when display "Save successful".

3) User Management

Select users: Set the user type (the default administrator, Common User 1, Common User 2 optional)

Username: Set the username (Select User Administrator default admin; select a common user1 default user1; to select a common user 2 default user2; user can modify their own)

Password: Set a password (Select User Administrator default admin; select a common user1 default user1; to select a common user 2 default user2; user can modify their own).

Password confirmation: Confirm the input passwords are the same or not.

Click on the "Save" button to display the "Save successfully" message, then the setting will take effect.

Note: Please note the case-sensitivity of the username and password.

If login page by a common user's name and password, one does not have configuration privileges but can only operate to preview, playback, logoff.

4) Version upgrade

MCU version V3.0.1 2021-01-07

Camera version V1.0.4 2021-01-07

Focus version V4.0.4 2015-12-11

Users only read the version information above which is consistent with the menu version but cannot modify.

Update file:

Click "Browse ..." installation, to select the upgrade file in the pop-up window.

Click on the "Upgrade" button, the upgrade dialog will appear. The device will reboot automatically after updating successfully.

(Note: Ensure the power and network is kept connected during the process or the upgrade will fail)

Note: After the version upgrade is complete, you need to restore factory defaults. Through web to restore the factory default configuration, or through the recovery menu, or remote-control shortcut "* # 6"

Choose one of the above three ways. If the first option is chosen, the IP accounts and passwords also need to be restored to the default.

5) Restore factory setting

Click on pop-up "Restore Factory Defaults" button and choose "yes" or "no", then the device will restart automatically and restore to factory default setting.

6) Reboot

Click on the pop-up "Reboot" button and choose "yes" or "no", then the device will restart automatically.

4.2.8 Logout

Point "Logout" pop-up "Confirmation" dialog; select "Yes" or "No", select "Yes" to exit the current page and return to the user login interface again.

5. Serial Communication Control

Under common working conditions, the camera could be controlled through RS232 / RS485 interface (VISCA). RS232C serial parameter are as follows:

Baud rate: 2400/4800/9600/115200 bits / sec; Start bit: 1; data bits: 8; Stop bit: 1; Parity: None.

After powering on, the camera will first go left, then back to the middle position. Self-test is only finished after the lens has moved to the farthest and then back to the nearest zoom position. If the camera saved 0 preset before, it will be back to that position after initialization. At this point, the user can control the camera by the serial commands.

5.1 VISCA protocol list

5.1.1 Camera return command

Ack/Completion Message		
	Command packet	Note
ACK	z0 41 FF	Returned when the command is accepted.
Completion	z0 51 FF	Returned when the command has been executed.

z = camera address + 8

Error Messages		
	Command packet	Note
Syntax Error	z0 60 02 FF	Returned when the command format is different or when a command with illegal command parameters is accepted
Command Not Executable	z0 61 41 FF	Returned when a command cannot be executed due to current conditions. For example, when commands controlling the focus manually are received during auto focus.

5.1.2 Camera control command

Command	Function	Command packet	Note
AddressSet	Broadcast	88 30 0p FF	p: Address setting
IF_Clear	Broadcast	88 01 00 01 FF	I/F Clear
CommandCancel		8x 21 FF	
CAM_Power	On	8x 01 04 00 02 FF	Power ON/OFF
	Off	8x 01 04 00 03 FF	
CAM_Zoom	Stop	8x 01 04 07 00 FF	p = 0(low) - F(high) pqrs: Zoom Position
	Tele(Standard)	8x 01 04 07 02 FF	
	Wide(Standard)	8x 01 04 07 03 FF	
	Tele(Variable)	8x 01 04 07 2p FF	
	Wide(Variable)	8x 01 04 07 3p FF	
	Direct	8x 01 04 47 0p 0q 0r 0s FF	
CAM_Focus	Stop	8x 01 04 08 00 FF	p = 0(low) - F(high) pqrs: Focus Position
	Far(Standard)	8x 01 04 08 02 FF	
	Near(Standard)	8x 01 04 08 03 FF	
	Far(Variable)	8x 01 04 08 2p FF	
	Near (Variable)	8x 01 04 08 3p FF	
	Direct	8x 01 04 48 0p 0q 0r 0s FF	
	Auto Focus	8x 01 04 38 02 FF	
	One Push Mode	8x 01 04 38 04 FF	
	Manual Focus	8x 01 04 38 03 FF	

Command	Function	Command packet	Note
CAM_Zoom Focus	Direct	8x 01 04 47 0p 0q 0r 0s 0t 0u 0v 0w FF	pqrs: Zoom Position tuvw: Focus Position
CAM_WB	Auto	8x 01 04 35 00 FF	
	3000K	8x 01 04 35 01 FF	
	4000k	8x 01 04 35 02 FF	
	One Push mode	8x 01 04 35 03 FF	
	5000k	8x 01 04 35 04 FF	
	Manual	8x 01 04 35 05 FF	
	6500k	8x 01 04 35 06 FF	
	3500K	8x 01 04 35 07 FF	
	4500K	8x 01 04 35 08 FF	
	5500K	8x 01 04 35 09 FF	
	6000K	8x 01 04 35 0A FF	
	7000K	8x 01 04 35 0B FF	
CAM_RGain	Reset	8x 01 04 03 00 FF	Manual Control of R Gain
	Up	8x 01 04 03 02 FF	
	Down	8x 01 04 03 03 FF	
	Direct	8x 01 04 43 00 00 0p 0q FF	pq: R Gain
CAM_Bgain	Reset	8x 01 04 04 00 FF	Manual Control of B Gain
	Up	8x 01 04 04 02 FF	
	Down	8x 01 04 04 03 FF	
	Direct	8x 01 04 44 00 00 0p 0q FF	pq: B Gain
CAM_AE	Full Auto	8x 01 04 39 00 FF	Automatic Exposure mode
	Manual	8x 01 04 39 03 FF	Manual Control mode
	Shutter priority	8x 01 04 39 0A FF	Shutter Priority Automatic Exposure mode
	Iris priority	8x 01 04 39 0B FF	Iris Priority Automatic Exposure mode
	Bright	8x 01 04 39 0D FF	Bright mode
CAM_Shutter	Reset	8x 01 04 0A 00 FF	Shutter Setting
	Up	8x 01 04 0A 02 FF	
	Down	8x 01 04 0A 03 FF	
	Direct	8x 01 04 4A 00 00 0p 0q FF	pq: Shutter Position
CAM_Iris	Reset	8x 01 04 0B 00 FF	Iris Setting
	Up	8x 01 04 0B 02 FF	
	Down	8x 01 04 0B 03 FF	
	Direct	8x 01 04 4B 00 00 0p 0q FF	pq: Iris Position
CAM_Gain Limit	Gain Limit	8x 01 04 2C 0p FF	p: Gain Positon
CAM_Bright	Reset	8x 01 04 0D 00 FF	Bright Setting
	Up	8x 01 04 0D 02 FF	
	Down	8x 01 04 0D 03 FF	
	Direct	8x 01 04 4D 00 00 0p 0q FF	pq: Bright Positon
CAM_ExpComp	On	8x 01 04 3E 02 FF	Exposure Compensation ON/OFF
	Off	8x 01 04 3E 03 FF	
	Reset	8x 01 04 0E 00 FF	Exposure Compensation Amount Setting
	Up	8x 01 04 0E 02 FF	
	Down	8x 01 04 0E 03 FF	
	Direct	8x 01 04 4E 00 00 0p 0q FF	pq: ExpComp Position
CAM_Back Light	On	8x 01 04 33 02 FF	Back Light Compensation
	Off	8x 01 04 33 03 FF	
CAM_WDRStrength	Reset	8x 01 04 21 00 FF	WDR Level Setting

Command	Function	Command packet	Note
	Up	8x 01 04 21 02 FF	
	Down	8x 01 04 21 03 FF	
	Direct	8x 01 04 51 00 00 00 0p FF	
CAM_NR (2D)		8x 01 04 53 0p FF	P=0-7 0:OFF
CAM_NR (3D)		8x 01 04 54 0p FF	P=0-8 0:OFF
CAM_Gamma		8x 01 04 5B 0p FF	p = 0 – 4 0: Default 1: 0.47 2: 0.50 3: 0.52 4: 0.55
CAM_Flicker	OFF	8x 01 04 23 00 FF	OFF
	50HZ	8x 01 04 23 01 FF	50HZ
	60HZ	8x 01 04 23 02 FF	60HZ
CAM_Aperture	Reset	8x 01 04 02 00 FF	Aperture Control
	Up	8x 01 04 02 02 FF	
	Down	8x 01 04 02 03 FF	
	Direct	8x 01 04 42 00 00 0p 0q FF	pq: Aperture Gain
CAM_Memory	Reset	8x 01 04 3F 00 pq FF	pq: Memory Number(=0 to 254) Corresponds to 0 to 9 on the Remote Commander
	Set	8x 01 04 3F 01 pq FF	
	Recall	8x 01 04 3F 02 pq FF	
CAM_LR_Reverse	On	8x 01 04 61 02 FF	Image Flip Horizontal ON/OFF
	Off	8x 01 04 61 03 FF	
CAM_PictureFlip	On	8x 01 04 66 02 FF	Image Flip Vertical ON/OFF
	Off	8x 01 04 66 03 FF	
CAM_ColorSaturation	Direct	8x 01 04 49 00 00 00 0p FF	P=0-7 0:60% 1:70% 2:80% 3:90% 4:100% 5:110% 6:120% 7:130%
CAM_IDWrite		8x 01 04 22 0p 0q 0r 0s FF	pqrs: Camera ID (=0000 to FFFF)
SYS_Menu	ON	8x 01 04 06 06 02 FF	Turn on the menu screen
	OFF	8x 01 04 06 06 03 FF	Turn off the menu screen
IR_Receive	ON	8x 01 06 08 02 FF	IR(remote commander)receive On/Off
	OFF	8x 01 06 08 03 FF	
IR_ReceiveReturn	On	8x 01 7D 01 03 00 00 FF	IR(remote commander)receive message via the VISCA communication ON/OFF
	Off	8x 01 7D 01 13 00 00 FF	
CAM_SettingReset	Reset	8x 01 04 A0 10 FF	Reset Factory Setting
CAM_Brightness	Direct	8x 01 04 A1 00 00 0p 0q FF	pq: Brightness Position
CAM_Contrast	Direct	8x 01 04 A2 00 00 0p 0q FF	pq: Contrast Position
CAM_Flip	OFF	8x 01 04 A4 00 FF	Single Command For Video Flip
	Flip-H	8x 01 04 A4 01 FF	
	Flip-V	8x 01 04 A4 02 FF	
	Flip-HV	8x 01 04 A4 03 FF	
CAM_VideoSystem	Set camera video system	8x 01 06 35 00 0p FF	P: 0~E Video format 0:1080P60 8:720P30 1:1080P50 9:720P25 2:1080i60 A: 1080P59.94 3:1080i50 B: 1080i59.94 4:720P60 C: 720P59.94 5:720P50 D: 1080P29.97 6:1080P30 E: 720P29.97 7:1080P25
Pan_tiltDrive	Up	8x 01 06 01 VV WW 03 01 FF	VV: Pan speed 0x01 (low speed) to 0x18 (high speed) WW: Tilt speed 0x01 (low speed) to 0x14 (high speed) YYYY: Pan Position ZZZZ: Tilt Position
	Down	8x 01 06 01 VV WW 03 02 FF	
	Left	8x 01 06 01 VV WW 01 03 FF	
	Right	8x 01 06 01 VV WW 02 03 FF	
	Upleft	8x 01 06 01 VV WW 01 01 FF	
	Upright	8x 01 06 01 VV WW 02 01 FF	

Command	Function	Command packet	Note
	DownLeft	8x 01 06 01 VV WW 01 02 FF	
	DownRight	8x 01 06 01 VV WW 02 02 FF	
	Stop	8x 01 06 01 VV WW 03 03 FF	
	AbsolutePosition	8x 01 06 02 VV WW 0Y 0Y 0Y 0Y 0Z 0Z 0Z 0Z FF	
	RelativePosition	8x 01 06 03 VV WW 0Y 0Y 0Y 0Y 0Z 0Z 0Z 0Z FF	
	Home	8x 01 06 04 FF	
	Reset	8x 01 06 05 FF	
Pan-tiltLimitSet	Set	8x 01 06 07 00 0W 0Y 0Y 0Y 0Y 0Z 0Z 0Z 0Z FF	W:1 UpRight 0:DownLeft YYYY: Pan Limit Position(TBD) ZZZZ: Tilt Limit Position(TBD)
	Clear	8x 01 06 07 01 0W 07 0F 0F 0F 07 0F 0F 0F FF	

5.1.3, Inquiry command

Command	Function	Command packet	Note
CAM_PowerInq	8x 09 04 00 FF	y0 50 02 FF	On
		y0 50 03 FF	Off(Standby)
CAM_ZoomPosInq	8x 09 04 47 FF	y0 50 0p 0q 0r 0s FF	pqrs: Zoom Position
CAM_FocusAFModelInq	8x 09 04 38 FF	y0 50 02 FF	Auto Focus
		y0 50 03 FF	Manual Focus
		y0 50 04 FF	One Push mode
CAM_FocusPosInq	8x 09 04 48 FF	y0 50 0p 0q 0r 0s FF	pqrs: Focus Position
CAM_WBModelInq	8x 09 04 35 FF	y0 50 00 FF	Auto
		y0 50 01 FF	3000K
		y0 50 02 FF	4000K
		y0 50 03 FF	One Push Mode
		y0 50 04 FF	5000K
		y0 50 05 FF	Manual
		y0 50 06 FF	6500K
		y0 50 07 FF	6500K
		y0 50 08 FF	3500K
		y0 50 09 FF	4500K
		y0 50 0A FF	5500K
		y0 50 0B FF	6000K
y0 50 0B FF	7000K		
CAM_RGainInq	8x 09 04 43 FF	y0 50 00 00 0p 0q FF	pq: R Gain
CAM_BGainInq	8x 09 04 44 FF	y0 50 00 00 0p 0q FF	pq: B Gain
CAM_AEModelInq	8x 09 04 39 FF	y0 50 00 FF	Full Auto
		y0 50 03 FF	Manual
		y0 50 0A FF	Shutter priority
		y0 50 0B FF	Iris priority
y0 50 0D FF	Bright		
CAM_ShutterPosInq	8x 09 04 4A FF	y0 50 00 00 0p 0q FF	pq: Shutter Position
CAM_IrisPosInq	8x 09 04 4B FF	y0 50 00 00 0p 0q FF	pq: Iris Position
CAM_Gain LimitInq	8x 09 04 2C FF	y0 50 0p FF	p: Gain Positon
CAM_BrightPosInq	8x 09 04 4D FF	y0 50 00 00 0p 0q FF	pq: Bright Position
CAM_ExpCompModelInq	8x 09 04 3E FF	y0 50 02 FF	On
		y0 50 03 FF	Off
CAM_ExpCompPosInq	8x 09 04 4E FF	y0 50 00 00 0p 0q FF	pq: ExpComp Position
CAM_BacklightModelInq	8x 09 04 33 FF	y0 50 02 FF	On
		y0 50 03 FF	Off
CAM_WDRStrengthInq	8x 09 04 51 FF	y0 50 00 00 00 0p FF	p: WDR Strength
CAM_NRLevel(2D) Inq	8x 09 04 53 FF	y0 50 0p FF	P: 2DNRLevel
CAM_NRLevel(3D) Inq	8x 09 04 54 FF	y0 50 0p FF	P:3D NRLevel
CAM_FlickerModelInq	8x 09 04 55 FF	y0 50 0p FF	p: Flicker Settings(0: OFF,1: 50Hz,2:60Hz)
CAM_ApertureInq	8x 09 04 42 FF	y0 50 00 00 0p 0q FF	pq: Aperture Gain
CAM_PictureEffectModelInq	8x 09 04 63 FF	y0 50 00 FF	Off
		y0 50 04 FF	B&W
CAM_MemoryInq	8x 09 04 3F FF	y0 50 0p FF	p: Memory number last operated.

SYS_MenuModelInq	8x 09 06 06 FF	y0 50 02 FF	On
		y0 50 03 FF	Off
CAM_LR_ReverseInq	8x 09 04 61 FF	y0 50 02 FF	On
		y0 50 03 FF	Off
CAM_PictureFlipInq	8x 09 04 66 FF	y0 50 02 FF	On
		y0 50 03 FF	Off
CAM_ColorSaturationInq	8x 09 04 49 FF	y0 50 00 00 00 0p FF	p: Color Gain setting 0h (60%) to Eh (130%)
CAM_IDInq	8x 09 04 22 FF	y0 50 0p FF	p: Gamma ID
IR_ReceiveInq	8x 09 06 08 FF	y0 50 02 FF	On
		y0 50 03 FF	Off
IR_ReceiveReturn		y0 07 7D 01 04 00 FF	Power ON/OFF
		y0 07 7D 01 04 07 FF	Zoom tele/wide
		y0 07 7D 01 04 38 FF	AF ON/OFF
		y0 07 7D 01 04 33 FF	Camera_Backlight
		y0 07 7D 01 04 3F FF	Camera_Memery
		y0 07 7D 01 06 01 FF	Pan_titleDriver
CAM_BrightnessInq	8x 09 04 A1 FF	y0 50 00 00 0p 0q FF	pq: Brightness Position
CAM_ContrastInq	8x 09 04 A2 FF	y0 50 00 00 0p 0q FF	pq: Contrast Position
CAM_FlipInq	8x 09 04 A4 FF	y0 50 00 FF	Off
		y0 50 01 FF	Flip-H
		y0 50 02 FF	Flip-V
		y0 50 03 FF	Flip-HV
CAM_GammaInq	8x 09 04 5B FF	y0 50 0p FF	p: Gamma setting
CAM_VersionInq	8x 09 00 02 FF	y0 50 ab cd mn pq rs tu vw FF	ab cd : vender ID (0220) mn pq : model ID ST (0950) U3 (3950) rs tu : ARM Version vw : reserve
VideoSystemInq	8x 09 06 23 FF	y0 50 0p FF	P: 0~E Video format 0:1080P60 8:720P30 1:1080P50 9:720P25 2:1080i60 A: 1080P59.94 3:1080i50 B: 1080i59.94 4:720P60 C: 720P59.94 5:720P50 D: 1080P29.97 6:1080P30 E: 720P29.97 7:1080P25
Pan-tiltMaxSpeedInq	8x 09 06 11 FF	y0 50 ww zz FF	ww: Pan Max Speed zz: Tilt Max Speed
Pan-tiltPosInq	8x 09 06 12 FF	y0 50 0w 0w 0w 0w 0z 0z 0z 0z FF	www: Pan Position zzzz: Tilt Position

Note:[X] in the above table indicates the camera address to be operated, **【y】 = 【x + 8】** .

5.2, Pelco-D protocol command list

Function	Byte1	Byte2	Byte3	Byte4	Byte5	Byte6	Byte7
Up	0xFF	Address	0x00	0x08	Pan Speed	Tilt Speed	SUM
Down	0xFF	Address	0x00	0x10	Pan Speed	Tilt Speed	SUM
Left	0xFF	Address	0x00	0x04	Pan Speed	Tilt Speed	SUM
Right	0xFF	Address	0x00	0x02	Pan Speed	Tilt Speed	SUM
Upleft	0xFF	Address	0x00	0x0C	Pan Speed	Tilt Speed	SUM
Upright	0xFF	Address	0x00	0x0A	Pan Speed	Tilt Speed	SUM
DownLeft	0xFF	Address	0x00	0x14	Pan Speed	Tilt Speed	SUM
DownRight	0xFF	Address	0x00	0x12	Pan Speed	Tilt Speed	SUM
Zoom In	0xFF	Address	0x00	0x20	0x00	0x00	SUM
Zoom Out	0xFF	Address	0x00	0x40	0x00	0x00	SUM
Focus Far	0xFF	Address	0x00	0x80	0x00	0x00	SUM
Focus Near	0xFF	Address	0x01	0x00	0x00	0x00	SUM
Set Preset	0xFF	Address	0x00	0x03	0x00	Preset ID	SUM
Clear Preset	0xFF	Address	0x00	0x05	0x00	Preset ID	SUM
Call Preset	0xFF	Address	0x00	0x07	0x00	Preset ID	SUM
Query Pan Position	0xFF	Address	0x00	0x51	0x00	0x00	SUM
Query Pan Position Response	0xFF	Address	0x00	0x59	Value High Byte	Value Low Byte	SUM
Query Tilt Position	0xFF	Address	0x00	0x53	0x00	0x00	SUM
Query Tilt Position Response	0xFF	Address	0x00	0x5B	Value High Byte	Value Low Byte	SUM
Query Zoom Position	0xFF	Address	0x00	0x55	0x00	0x00	SUM
Query Zoom Position Response	0xFF	Address	0x00	0x5D	Value High Byte	Value Low Byte	SUM

5.3 Pelco-P protocol command list

Function	Byte1	Byte2	Byte3	Byte4	Byte5	Byte6	Byte7	Byte8
Up	0xA0	Address	0x00	0x08	Pan Speed	Tilt Speed	0xAF	XOR
Down	0xA0	Address	0x00	0x10	Pan Speed	Tilt Speed	0xAF	XOR
Left	0xA0	Address	0x00	0x04	Pan Speed	Tilt Speed	0xAF	XOR
Right	0xA0	Address	0x00	0x02	Pan Speed	Tilt Speed	0xAF	XOR
Upleft	0xA0	Address	0x00	0x0C	Pan Speed	Tilt Speed	0xAF	XOR
Upright	0xA0	Address	0x00	0x0A	Pan Speed	Tilt Speed	0xAF	XOR
DownLeft	0xA0	Address	0x00	0x14	Pan Speed	Tilt Speed	0xAF	XOR
DownRight	0xA0	Address	0x00	0x12	Pan Speed	Tilt Speed	0xAF	XOR
Zoom In	0xA0	Address	0x00	0x20	0x00	0x00	0xAF	XOR
Zoom Out	0xA0	Address	0x00	0x40	0x00	0x00	0xAF	XOR
Focus Far	0xA0	Address	0x01	0x00	0x00	0x00	0xAF	XOR
Focus Near	0xA0	Address	0x02	0x00	0x00	0x00	0xAF	XOR
Set Preset	0xA0	Address	0x00	0x03	0x00	Preset ID	0xAF	XOR
Clear Preset	0xA0	Address	0x00	0x05	0x00	Preset ID	0xAF	XOR
Call Preset	0xA0	Address	0x00	0x07	0x00	Preset ID	0xAF	XOR
Query Pan Position	0xA0	Address	0x00	0x51	0x00	0x00	0xAF	XOR
Query Pan Position Response	0xA0	Address	0x00	0x59	Value High Byte	Value Low Byte	0xAF	XOR
Query Tilt Position	0xA0	Address	0x00	0x53	0x00	0x00	0xAF	XOR
Query Tilt Position Response	0xA0	Address	0x00	0x5B	Value High Byte	Value Low Byte	0xAF	XOR
Query Zoom Position	0xA0	Address	0x00	0x55	0x00	0x00	0xAF	XOR
Query Zoom Position Response	0xA0	Address	0x00	0x5D	Value High Byte	Value Low Byte	0xAF	XOR

6. Camera Maintenance and Troubleshooting

6.1 Camera Maintenance

- 1) If camera is not in use for long time, please turn off power adapter switch and the outlet.
- 2) Use soft cloth or tissue to clean the camera cover.
- 3) Use a soft cloth to clean the lens. Use neutral cleanser if smudged or smeared. Do not use a strong or corrosive cleanser.

6.2 Troubleshooting

1) No video output:

- A. Check whether the camera power supply is connected, if the voltage is normal and if the power indicator is lit.
- B. Whether the camera could do a self-inspection after restarting.
- C. Check whether the video output cable or video display is functional.

2) Intermittent image:

- A. Check whether the video output cable or video display is functional.

3) Image dithering when zoom-in or zoom-out

- A. Check whether the camera installation position is level and solid
- B. Whether there is device that vibrates or shakes or if there are objects around the camera

4) Remote controller failure

- A. Remote control address is set to 1 (if the camera is set back to the factory defaults, remote control addresses need to be put back to 1 too)
- B. Check if there are batteries in the remote controller or if the batteries still have charge.
- C. Check if the cameras working mode is the normal operating mode (see Table 2.2 and Table 2.3)
- D. Check whether the menu is closed, camera control through remote controller is only available after exiting the OSD menu. If video output is from LAN, the menu will not be displayed, menu will automatically exist 30s later, and then it can be controlled by remote controller.

5) Serial port error.

- A. Check whether the camera serial device protocol, baud rate, and address is consistent.
- B. Check whether the control cable is connected properly.
- C. Check whether the camera working mode is the normal operating mode (see Table 2.2 and Table 2.3)

6) Web pages log in issue

- A. Check whether the camera is showing normally.
- B. Check whether the network cable is connected properly (Ethernet port yellow light flashes to indicate normal network cable connection)
- C. Check whether your computer has added the segment and the segment is consistent with the IP address of the camera
- D. Click "Start" and select "Run" and then type "CMD" in the computer; Click "OK" then turn on a DOS command window to enter ping 192.168.5.163. Press the Enter key and the message appears as follows: Description network connection is normal

```
C:\Users\qq214>ping 192.168.5.163

Pinging 192.168.5.163 with 32 bytes of data:
Reply from 192.168.5.163: bytes=32 time=2ms TTL=64
Reply from 192.168.5.163: bytes=32 time=1ms TTL=64
Reply from 192.168.5.163: bytes=32 time<1ms TTL=64
Reply from 192.168.5.163: bytes=32 time=4ms TTL=64

Ping statistics for 192.168.5.163:
    Packets: Sent = 4, Received = 4, Lost = 0 (0% loss),
    Approximate round trip times in milli-seconds:
        Minimum = 0ms, Maximum = 4ms, Average = 1ms

C:\Users\qq214>_
```

7. Warranty

Limited warranty in respect of Alfatron Products

1.1 This limited warranty covers defects in materials and workmanship in this product.

1.2 Should warranty service be required, proof of purchase must be presented to the Company. The serial number on the product must be clearly visible and not have been tampered with in any way whatsoever.

1.3 This limited warranty does not cover any damage, deterioration or malfunction resulting from any alteration, modification, improper or unreasonable use or maintenance, misuse, abuse, accident, neglect, exposure to excess moisture, fire, improper packing and shipping (such claims must be presented to the carrier), lightning, power surges, or other acts of nature. This limited warranty does not cover any damage, deterioration or malfunction resulting from the installation or removal of this product from any installation, any unauthorized tampering with this product, any repairs attempted by anyone unauthorized by the Company to make such repairs, or any other cause which does not relate directly to a defect in materials and/or workmanship of this product. This limited warranty does not cover equipment enclosures, cables or accessories used in conjunction with this product.

This limited warranty does not cover the cost of normal maintenance. Failure of the product due to insufficient or improper maintenance is not covered.

1.4 The Company does not warrant that the product covered hereby, including, without limitation, the technology and/or integrated circuit(s) included in the product, will not become obsolete or that such items are or will remain compatible with any other product or technology with which the product may be used.

1.5 Only the original purchaser of this product is covered under this limited warranty. This limited warranty is not transferable to subsequent purchasers or owners of this product.

1.6 Unless otherwise specified, the goods are warranted in accordance with the manufacturer's product specific warranties against any defect attributable to faulty workmanship or materials, fair wear and tear being excluded.

1.7 This limited warranty only covers the cost of faulty goods and does not include the cost of labor and travel to return the goods to the Company's premises.

1.8 In the event of any improper maintenance, repair or service being carried out by any third persons during the warranty period without the Company's written authorization, the limited warranty shall be void.

1.9 A 7 (seven) year limited warranty is given on the aforesaid product where used correctly according to the Company's instructions, and only with the use of the Company's components.

1.10 The Company will, at its sole option, provide one of the following three remedies to whatever extent it shall deem necessary to satisfy a proper claim under this limited warranty:

1.10.1 Elect to repair or facilitate the repair of any defective parts within a reasonable period of time, free of any charge for the necessary parts and labor to complete the repair and restore this product to its proper operating condition.; or

1.10.2 Replace this product with a direct replacement or with a similar product deemed by the Company to perform substantially the same function as the original product; or

1.10.3 Issue a refund of the original purchase price less depreciation to be determined based on the age of the product at the time remedy is sought under this limited warranty.

1.11 The Company is not obligated to provide the Customer with a substitute unit during the limited warranty period or at any time thereafter.

1.12 If this product is returned to the Company this product must be insured during shipment, with the insurance and shipping charges prepaid by the Customer. If this product is returned uninsured, the Customer assumes all risks of loss or damage during shipment. The Company will not be responsible for any costs related to the removal or re-installation of this product from or into any installation. The Company will not be responsible for any costs related to any setting up this product, any adjustment of user controls or any programming required for a specific installation of this product.

1.13 Please be aware that the Company's products and components have not been tested with competitor's products and therefore the Company cannot warrant products and/or components used in conjunction with competitor's products.

1.14 The appropriateness of the goods for the purpose intended is only warranted to the extent that the goods are used in accordance with the Company's installation, classification and usage instructions.

1.15 Any claim by the Customer which is based on any defect in the quality or condition of the goods or their failure to correspond with specification shall be notified in writing to the Company within 7 days of delivery or (where the defect or failure was not apparent on reasonable inspection by the Customer) within a reasonable time after discovery of the defect or failure, but, in any event, within 6 months of delivery.

1.16 If delivery is not refused, and the Customer does not notify the Company accordingly, the Customer may not reject the goods and the Company shall have no liability and the Customer shall pay the price as if the goods had been delivered in accordance with the Agreement.

THE MAXIMUM LIABILITY OF THE COMPANY UNDER THIS LIMITED WARRANTY SHALL NOT EXCEED THE ACTUAL PURCHASE PRICE PAID FOR THE PRODUCT